

TYLER

Allegro
S E R I E S™

Installation & Service Manual

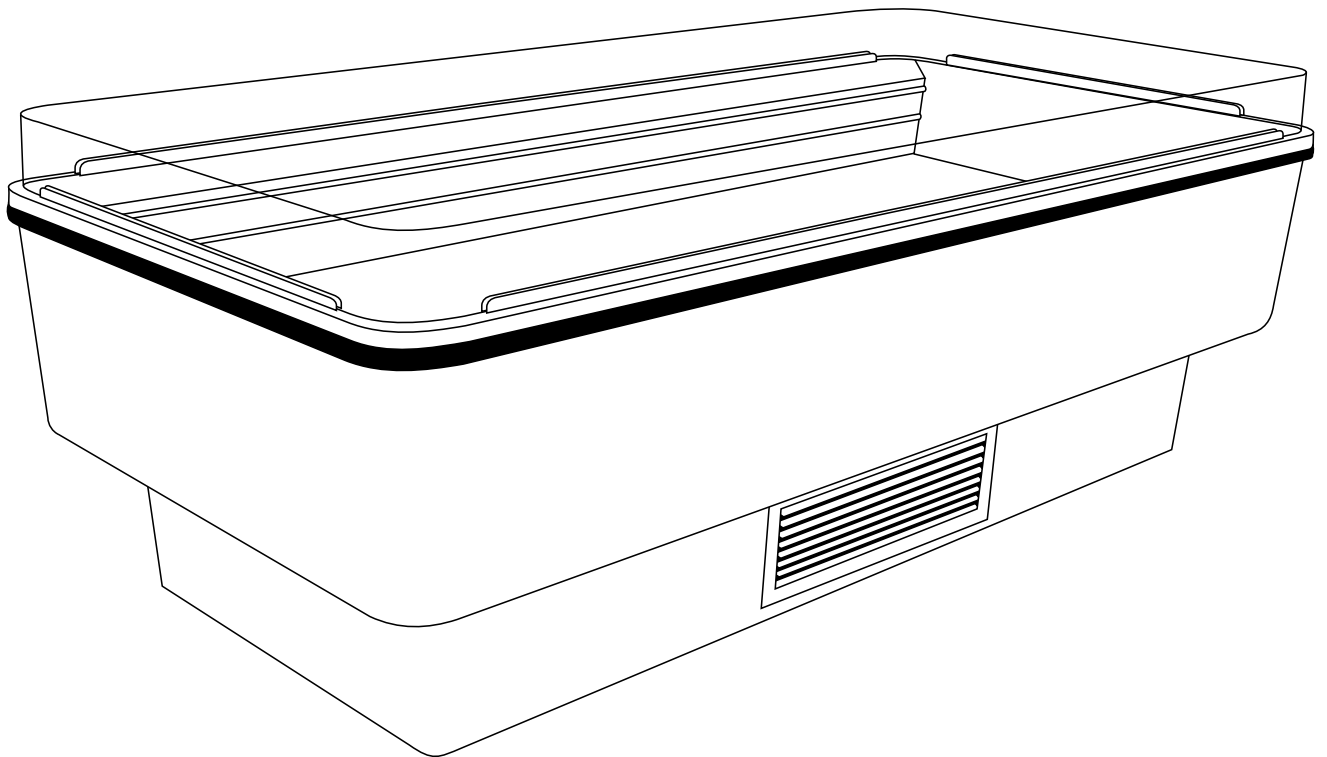

LDSSI

SELF-SERVICE DELI ISLAND MERCHANDISER
Medium Temperature Self Serve Display Cases

This manual has been designed to be used in conjunction with the General
(UL/NSF) Installation & Service Manual.

Save the Instructions in Both Manuals for Future Reference!!

This merchandiser conforms to the American National Standard Institute & NSF International Health and Sanitation standard ANSI/NSF 7 - 1999.

PRINTED IN U.S.A.	Specifications subject to change without notice.	REPLACES EDITION	ISSUE DATE	5/04	PART NO.	9805002	REV.
-------------------	--	------------------	------------	------	----------	---------	------

Tyler Refrigeration * Niles, Michigan 49120

CONTENTS

	<u>Page</u>
Specifications	
LDSSI Specification Sheets	4
Line Sizing Requirements (See General-UL/NSF I&S Manual)	
Pre-Installation Responsibilities (See General-UL/NSF I&S Manual)	
Installation Procedures	
Carpentry Procedures	5
Plumbing Procedures (See General-UL/NSF I&S Manual)	
Refrigeration Procedures (See General-UL/NSF I&S Manual)	
Electrical Procedures	5
Electrical Considerations	5
Defrost Information	5
Defrost Control Chart	5
Installation Procedure Check Lists (See General-UL/NSF I&S Man.)	
Wiring Diagrams	6
LDSSI Domestic & Export (50Hz) Case Circuits	6
Cleaning and Sanitation (See General-UL/NSF I&S Manual)	
Component Removal and Installation Instructions for Cleaning	7
Screens	7
Bottom Trays	7
Discharge Air Honeycomb	7
Rear Air Duct Panels	7
Front Air Ducts Panels	7
Base Access Panel	7
Plexiglas Care	7
Cleaning	7
Waxing	7

	<u>Page</u>
General Information	
NSF Product Thermometer Installation	8
Radiant Heat Information	8
Radiant Heat Measurement	8
Display Practices	8
Service Instructions	
Preventive Maintenance (See General-UL.NSF I&S Manual)	
Fan Blade and Motor Replacement (See General-UL/NSF I&S Man.)	
NSF Product Thermometer Replacement	9
Perimeter Plexiglas Replacement	9
Bumper Replacement	10
Lower Access Panel Removal	10
Parts Information	
Operational Parts List	11
TYLER Warranty (See General-UL/NSF I&S Manual)	

The following Medium Temperature Self-Service Deli Island Merchandiser models are covered in this manual:

MODEL	DESCRIPTION
LDSSI	8' SELF-SERVICE DELI ISLAND MERCHANDISER
LDSSI	12' SELF-SERVICE DELI ISLAND MERCHANDISER

SPECIFICATIONS

LDSSI Self-Service Medium Temperature Deli Island Merchandisers

Refrigeration Data:

MODEL	CASE LENGTH	CASE USAGE	CAPACITY (BTUH / FT)		EVAPORATOR (°F)	UNIT SIZING (°F)	DISCHARGE AIR		AVG. REF. CHARGE (LBS/FT)
			PARALLEL	CONVENTIONAL			TEMPERATURE (°F)	VELOCITY (FPM)	
LDSSI	8'/12'	MED TEMP	314*	336*	+21**	+19	+28.5	260***	1.82****

- * For sizing all refrigeration equipment other than TYLER, use conventional BTUH values.
- ** Evaporator temperature is based on the saturated pressure leaving the case.
- *** Air velocity measured 1 hour after defrost at the discharge air duct using an ALNOR JR. velometer with a scoop.
- **** This is an average refrigeration charge per foot based on R22 and R404A refrigerant usage.

FOR SPECIFIC COMPRESSOR SIZING AND/OR LINE SIZING INFORMATION, REFER TO THE "GOLD" AND/OR "BUFF" SECTIONS IN THE TYLER SPECIFICATION GUIDE.

Electrical Data:

Fans and Heaters (120 Volt)

MODEL	CASE LENGTH	FANS / CASE	TOTAL STANDARD FANS		TOTAL ECM FANS		TOTAL ANTI-SWEATS (120V)	
			AMPS	WATTS	AMPS	WATTS	DISCHARGE AIR AMPS	WATTS
LDSSI	8'	2	0.68	60.4	0.44	22.0	N/A	N/A
LDSSI	12'	3	1.02	90.6	0.66	33.0	N/A	N/A

Defrost Data:

DEFROST TYPE	DEFROSTS PER DAY	DURATION TIME (MIN)	TERMINATION (°F)	EPR SETTINGS *		DEFROST WATER (LB / FT / DAY)
				R22 (PSIG)	R404A (PSIG)	
TIME OFF	4	40	---	44	57	0.3

* Set EPR to give this pressure at the case.

LDSSI CROSS SECTION

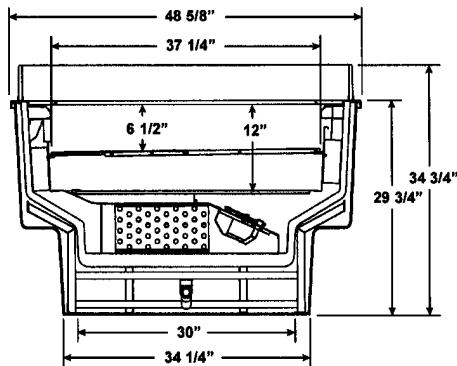

LDSSI FLOOR PLAN

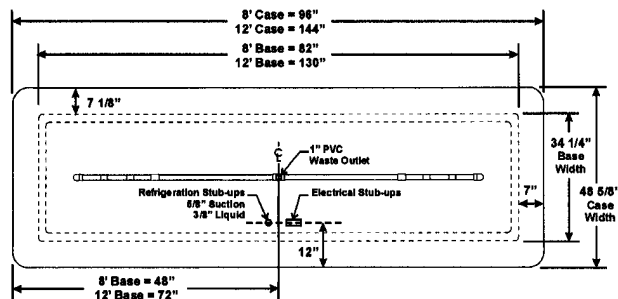

UL SANITATION approved in accordance with ANSI/NSF 7.

CASE BTUH REQUIREMENTS are calculated to produce approximately the indicated entering-air temperature with absolute maximum operating ambient limits of 75°F & 55RH.

The information contained herein is based on technical data and tests that we believe are reliable, and is intended for use by persons having technical skill at their own discretion and risk. Since conditions of use are outside of Tyler's control, we cannot assume any liability for results obtained or damages incurred through the applications of the data presented. SPECIFICATIONS ARE SUBJECT TO CHANGE WITHOUT NOTICE.

INSTALLATION PROCEDURES

Carpentry Procedures

The LDSSI models do not require any specific carpentry procedures. The cases are shipped as complete islands. Make sure the floor is level where the cases are to be installed. Electrical, refrigeration and drain access should be located under the cases.

After island case is installed, install the bottom trays, the case screens and the base access panel.

Refrigeration Procedures

See "General-UL.NSF I&S Manual" for general system, control and superheat information.

Electrical Procedures

Electrical Considerations

CAUTION

Make sure all electrical connections are tight. This prevents burning of electrical terminals and/or premature component failure.

NOTE

The electrical box, behind the base access panel, houses the electrical terminal block and wiring for the case. The electrical box covers will be shipped loose.

Case Fan Circuit

This circuit is to be supplied by an uninterrupted, protected 120V circuit. The case fan circuit is not cycled.

Defrost Information

See "General-UL/NSF I&S Manual" for operational descriptions for each type of defrost control.

Defrost Control Chart

Defrost Type	Defrosts Per Day	Defrost Duration (Min)	Term. Temp.
Off Time	4	40	-----

WIRING DIAGRAMS

ELECTRICIAN NOTE - OVERCURRENT PROTECTION

120V circuits should be protected by 15 or 20 Amp devices per the requirements noted on the cabinet nameplate or the National Electrical Code, Canadian Electrical Code - Part 1, Section 28. 208V defrost circuits employ No. 12 AWG field wire leads for field connections. On remote cases intended for end to end line-ups, bonding for ground may rely upon the pull-up bolts.

The following wiring diagram on page 6 covers all the LDSSI case circuits.

LDSSI Domestic & Export (50Hz) Case Circuits (8' & 12' Island Cases)



PART TYPE N T S 1. TYLER REGENERATION CORP. CLAIMS RIGHTS
 MODEL 2. INFORMATION IS FOR ENGINEERING USE ONLY
 FABRICATED X 3. ALL DIMENSIONS ARE IN INCHES UNLESS
 PURCHASED 4. SPECIFIED OTHERWISE FINISHED PART AFTER
 DEPT CC # 5. NO DIMENSIONAL RESTRICTIONS ALLOWED.

EVAPORATOR FAN MOTORS : 12FT (3) PER CASE
 8FT (2) PER CASE

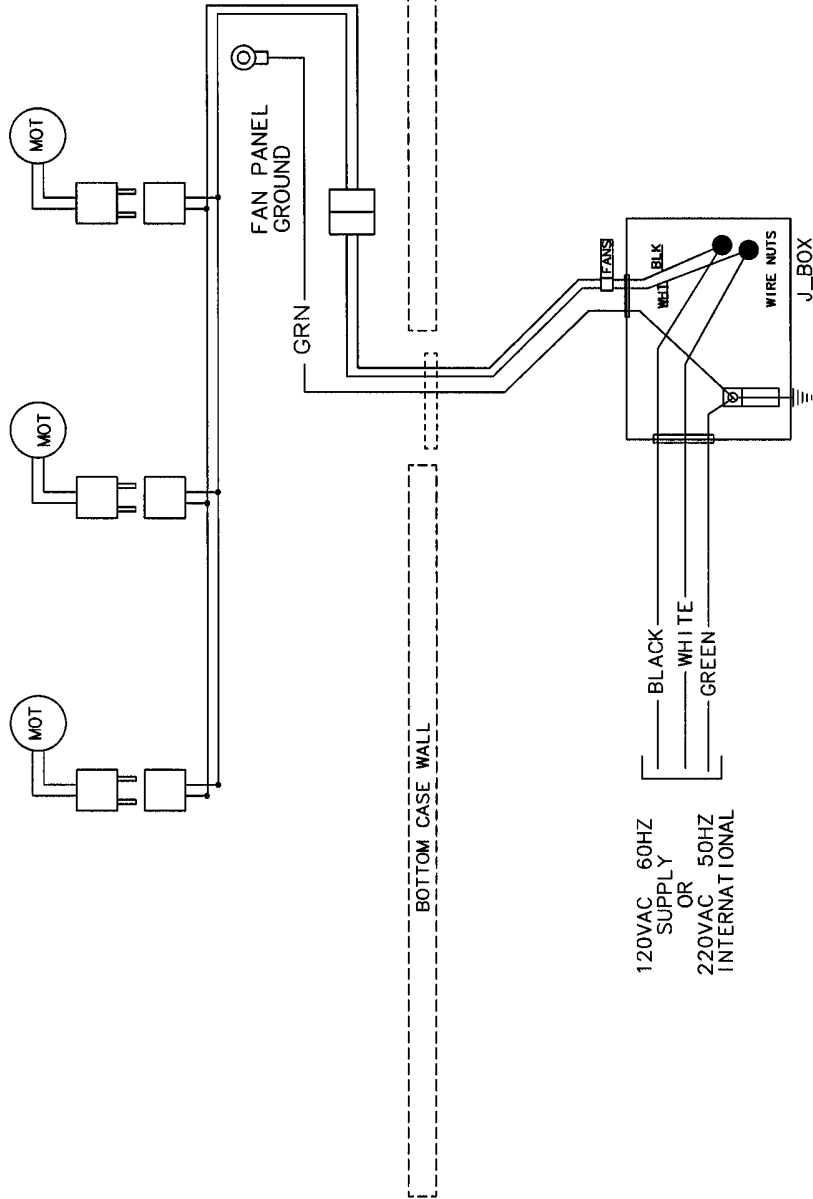

NOTE : ALL CASES MUST BE GROUNDED

DECIMALS +/- .030 ANGLES +/- 1 DEG	NAME	DATE	REV	BY	CHK	DATE	DESCRIPTION
	16 JUL 03						
	LC						DIAGRAM WRG
	AS						LDSSI_8_12
	000						9050396

CLEANING AND SANITATION

Component Removal and Installation Instructions for Cleaning

Screens

1. Remove product from screens.
2. Push screens back until front screen tabs clear the holes in the front duct.
3. Remove screens from holes in rear duct panels and from case.
4. After cleaning, replace in reverse order.

Bottom Trays

1. Remove product and screens from case. See this page.
2. Grasp and lift out each of the bottom trays from the case interior.
3. After cleaning, replace in reverse order.

Discharge Air Honeycomb

1. Remove screws and bottom retainer strip from rear interior of case.

NOTE

Note position of the honeycomb grid during removal so it can be reinstalled the same way.

2. Remove honeycomb grid sections from the rear duct.

CAUTION

Improper installation of the honeycomb grid section could result in improper air flow and/or poor refrigeration.

3. After cleaning, replace honeycomb grid sections as they were removed and secure with the bottom retainer strip and screws.

Rear Air Duct Panels

1. Remove screens, bottom trays and discharge air honeycomb, see this page.
2. Remove mounting screws from rear duct panel.
3. After cleaning, replace in reverse order.

Front Air Duct Panels

1. Remove screens and bottom trays, see this page.
2. Remove screws and front air duct panels from case.
3. After cleaning, replace in reverse order.

Base Access Panel

NOTE

Note position of the base access panel during removal so it can be reinstalled the same way.

1. Remove screws and base access panel from lower front section of the case.
2. After cleaning base access panel and under the case, replace the base access panel and secure with screws.

Plexiglas Care

Cleaning

CAUTION

DO NOT use paper towels, soft cloths, sponges or chamois to clean plexiglas. These materials will scratch the acrylic surface.

Clean with lukewarm water and plenty of nonabrasive soap, or detergent. Use only bare hand to dislodge any caked-on dirt. Lightly dry with a clean damp chamois or clean soft cloth.

Waxing

Wax should be applied in a thin even coat, and brought to a high polish by rubbing lightly with a dry clean soft cloth. Excessive rubbing may cause scratching and/or buildup an electrostatic charge, which attracts dust and dirt to the surface. Electrostatic charge can be removed by blotting acrylic surface with a clean damp cloth.

GENERAL INFORMATION

NSF Product Thermometer Installation

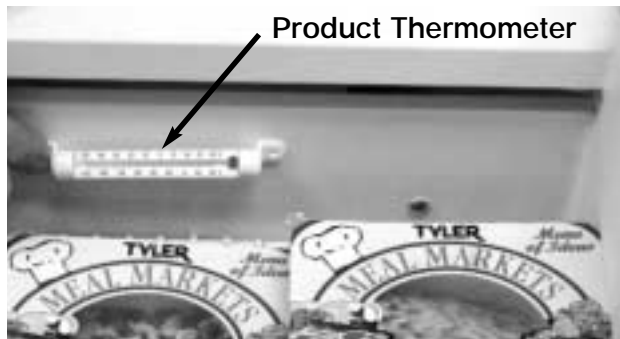

Install and secure a new product thermometer with two screws below the return air duct on the left end of the case.

Radiant Heat Information

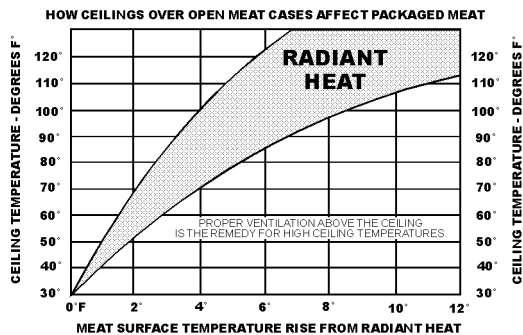
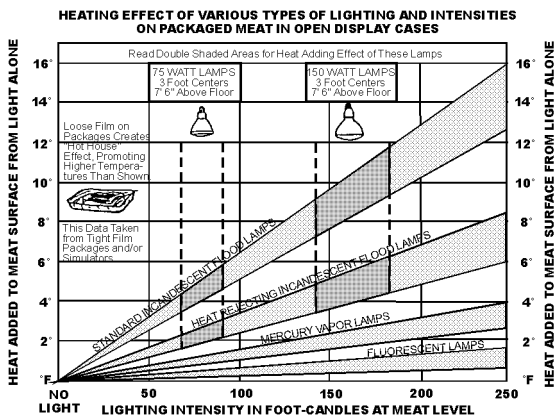

A wide temperature range is shown for each type of lighting. This data does not show all situations. Many situations will have higher package warm-up figures than indicated.

It is generally known that the temperature of displayed meat in refrigerated cases will run higher than the circulated air temperature of

the cases. A dial thermometer stuck into the center of a piece of meat compared with one in the air stream quickly confirms this fact. Another fact is that the surface temperature of the meat will be higher than the center temperature due to radiant heat. TYLER's ongoing research identifies sources of radiant heat and accurately measures and records it. These charts were developed from the information gathered during this research. Two major sources of radiant heat are from display lights and ceiling surfaces. Additional heat sources come from bad display practices which either overload the case with product or allow voids in the product display. Poor display practices impair the efficiency of the refrigeration, adding to the surface temperature of the meat. Bacteria and molds grow when surface temperatures rise above 45°F. This prematurely discolors displayed meats and causes unnecessary meat department losses.

Radiant Heat Measurement

Place two accurate dial thermometers side by side in a case. Cover one of the thermometer stems with black friction tape. The temperature difference is the approximate amount of radiant heat. A change in display lighting or a reduction of high ceiling temperatures (over 80°F) could reduce the radiant heat in the case.

Display Practices

Encourage butchers to maintain all meat below the case load lines and to eliminate product voids. Case screens could be covered in some instances to keep the refrigerated air over the display.

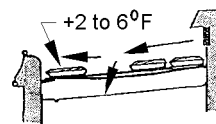

Voids in display raise surface temperature of package in front of void 2 to 6° F.

CAUTION

The quality damage done to meat products by high temperatures and/or contamination during delivery, cooler storage, cutting and wrapping cannot be repaired by placing the products into properly operating display cases.

SERVICE INSTRUCTIONS

See "General-UL/NSF I&S Manual" for fan blade and motor replacement.

NSF Product Thermometer Replacement

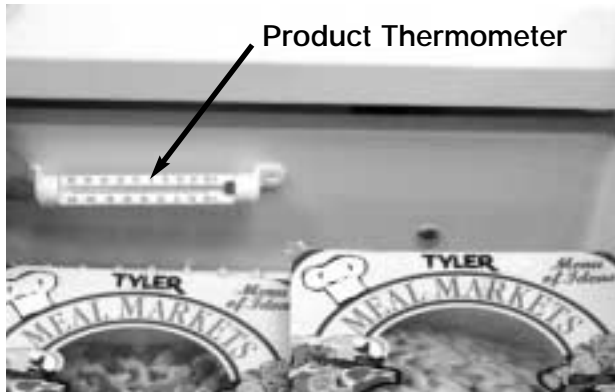

1. Remove two screws and the product thermometer from location below the left front return air duct on the case.
2. Install and secure the new product thermometer with two screws on the case in the same location as it was previously installed.

Perimeter Plexiglas Replacement

Perimeter plexiglas comes in four sections. Each section runs the top perimeter of 1/4 of the case. After installation, the four sections are adhered together into one piece.

1. Carefully cut apart sections of plexiglas at the joints. Remove broken or damaged plexiglas.

CAUTION

Make sure ends of adjoining plexiglas are clean and dry.

3. Using a sanding block, sand all adjoining edges of plexiglas to ensure, smooth even edges.
4. Measure and cut replacement section of the plexiglass, if necessary, to approximately 1/4" longer than opening. Block sand edges to make sure they are even and smooth.

5. Position and align new section of plexiglas in the opening and set bottom of plexiglas in lower track.

CAUTION

Avoid cement touching clear plexiglas surfaces. If contact occurs, the surface will scar and the final appearance may be unsatisfactory.

6. Using a downing fixture, align the top edge of plexiglas joint seam. Carefully apply acrylic adhesive (Weldon #1802) to joint seam from the outside surface of the plexiglas. Let adhesive dry for 5 minutes.
7. Using the same downing fixture, drill a 1/4" hole through the top of the plexiglas joint seam. Remove the downing fixture.
8. Apply acrylic adhesive to 1/4" acrylic dowel pin and insert the pin in top hole. Let acrylic adhesive dry for 5 minutes, then cut off excess dowel pin and file smooth.

Plexiglas Finishing Procedure

1. If joint seam of plexiglas does not match perfectly, grind uneven seam with #36 grit disc until seam is even. The finish area should be approximately 4 inches wide.
2. Dry sand using #80 grit sand paper. Increase width of finish area approximately 1/4" on each side.
3. Repeat step 2 using #280 grit sand paper.
4. Repeat step 2 using #400 grit sand paper.
5. Wet sand finish area using #800 grit sand paper.
6. Repeat step 5 using #1000 grit sand paper.
7. Repeat step 5 using #1500 grit sand paper.
8. Using a buffer, apply Novus brand heavy scratch remover #3 until smooth.
9. Repeat step 8 using Novus brand fine scratch remover #2.
10. Polish the finish area using a clean soft cloth and Novus brand Plastic Clean and Shine #1.

Bumper Replacement

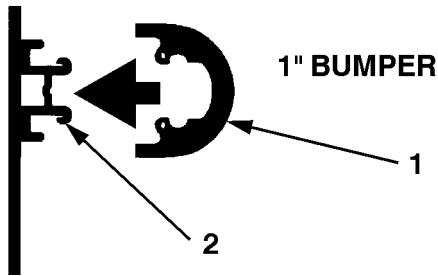

1. Find the bumper joint and pry one end of the bumper (1) until it start to release from the bumper retainer (2).
2. Grasp the loose end of the bumper (1) and pull firmly to peel bumper (1) off the bumper retainer (2).
3. Use old bumper as a guide to cut new bumper to the proper length.
4. Starting at one end, snap the new bumper (1) onto the bumper retainer (2).

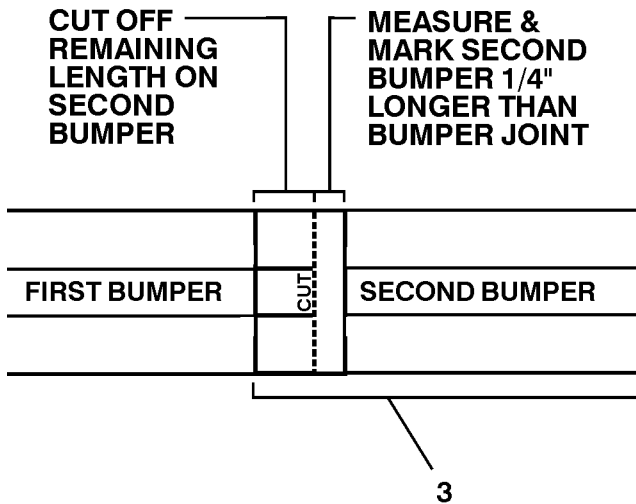

5. If more than one piece of bumper needs to be used to completely go around the case, measure and cut the second piece of bumper (3) 1/4" longer than the remaining space between the bumper ends.

NOTE

The center of the second piece of bumper may need to be snapped into place with a wooden block and a hammer.

6. Starting at both ends and working towards the center, snap the second piece of bumper (3) onto the bumper retainer (2).

NOTE

Bumpers will shrink when the cases are at operating temperature.

Lower Access Panel

There are two lower access panels on this case; one on the front base and one on the rear base. Both of these panel provide access to the drain and/or refrigeration lines to this caes. They also provide access for cleaning under the case.



1. To remove a lower access panel, remove six screws and lower access panel (1) from the base (2) of the case.
2. After completing case maintenance and/or cleaning under the case, replace the lower access panel (1) and secure to base (2) with screws.

PARTS INFORMATION

Operational Parts List

Case Usage	Domestic	
Electrical Circuit	115 Volt 60 Hertz	
Case Size	8'	12'
Fan Motor	5125532 5 Watt	5125532 5 Watt
Fan Motor Brackets	5962269	5962269
Fan Bracket Plate	9041077	9041077
Fan Blades (7.00" 15° 5B)	5223891	5223891
Opt. ECM Fan Motor	9025002 8 Watt	9025002 8 Watt
Opt. ECM Fan Motor Brackets	5205005	5205005
Opt. ECM Fan Blades (7.00" 20° 5B)	5960943	5960943
NSF Product Thermometer	5967100	5967100

For information on operational parts not listed above contact the TYLER Service Parts Department.