

N2MHP

TC Coil™



N2MHP semi-vertical merchandisers work well in wall lineups, or in back-to-back configurations. This versatile three-deck high performance meat merchandiser can creatively display meats, dairy, deli, pizza, baked goods, and critical temperature produce within various departments.

High Performance TC Coil™

High Performance (HP) Merchandisers feature our patented TC Coil™ design, which represents a major technology breakthrough for the commercial refrigeration industry. Developed jointly by Carrier Corporation and Tyler, the TC Coil enables HP merchandisers to operate more efficiently, providing energy savings that allow faster payback periods for food retailers.

Note: For more information about Tyler high performance display merchandisers featuring TC Coil, go to the Technologies section of this catalog on page 8.

Features & Benefits

- ♦ Energy-efficient copper tube and aluminum fin coils.
- ♦ 18" top shelf adds merchandising flexibility.
- ♦ Single row of T8 canopy lights for increased product illumination.
- ♦ Adjustable white powder-coated screen trays enhance product presentation.
- ♦ Solid steel base adds strength and durability.
- ♦ Easily removable interior components for quicker cleaning.
- ♦ Off-cycle defrost.

Options

- ♦ ECM fan motors for additional energy savings.
- ♦ Energy-efficient T8 shelf lighting with remote electronic ballasts.
- ♦ Multiple-depth shelving alternatives.
- ♦ 3 or 6 position shelf brackets for varied shelf display angles.

Specifications are subject to engineering changes without notice.

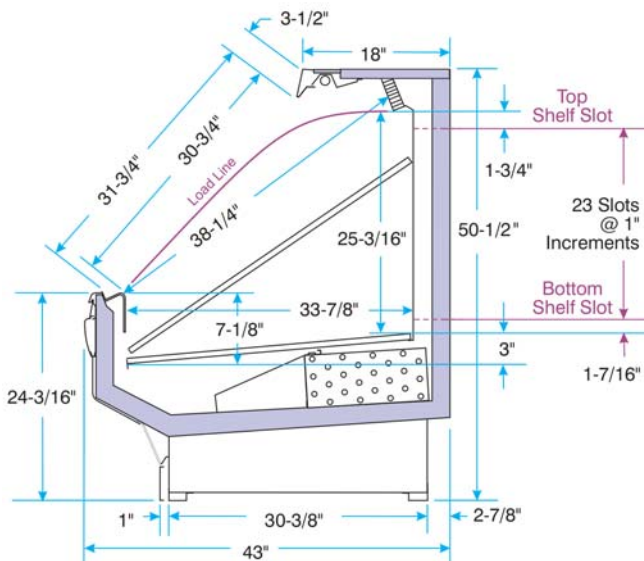

Model	Case Length	Description	Capacity in Cubic Feet*
N2MHP	6' • 8' • 12'	Solid Front, 3-Deck, TC Coil	23.0 • 30.7 • 46.1

* Cubic capacity is based on one row of 15" shelves and one row of 18" shelves.

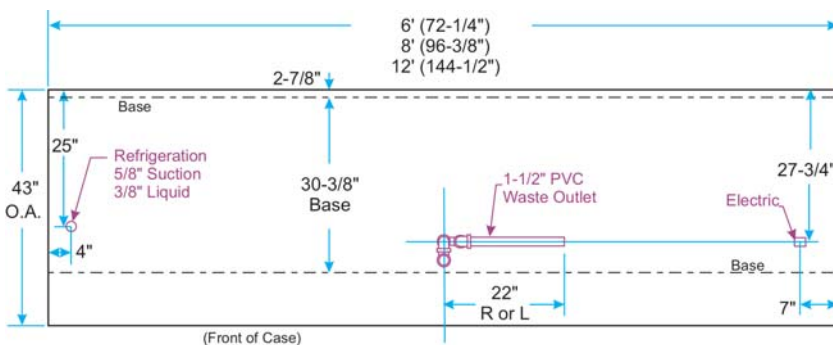

Note: Add 1-1/2" to case length for each standard patch end.