

SPECIFICATION SHEET

- **N3HMHP SOLID FRONT 3 DECK HIGH PERF. MED TEMP MERCHANDISERS •**
- **N3HMGHP GLASS FRONT 3 DECK HIGH PERF. MED TEMP MERCHANDISERS •**

Refrigeration Data:

MODEL	CASE LENGTH	CASE USAGE	CAPACITY (BTUH / FT)		EVAPORATOR (°F)	UNIT SIZING (°F)	DISCHARGE AIR		AVG. REF. CHARGE (LBS/FT)
			PARALLEL	CONVENTIONAL			TEMPERATURE (°F)	VELOCITY (FPM)	
N3HMHP	6'/8'/12'	MED TEMP	1,055*	1,195*	+25**	+23	+28.4	188***	0.48
N3HMGHP	6'/8'/12'	MED TEMP	971*	1,099*	+25**	+23	+28.4	188***	0.48

* Capacity data listed for cases with optional 2 rows of T-8 canopy lights and 3 rows of optional lighted shelves. Adjustments must be made to this base rating for each option installed on this case. DEDUCT 23 BTUH/FT for each row of unlighted shelves. For sizing all refrigeration equipment other than TYLER, use conventional BTUH values.

** Evaporator temperature is defined as the saturated suction temperature leaving the case.

*** Air velocity measured 1 hour after defrost at the top discharge air duct using an ALNOR JR. velometer with a scoop.

FOR SPECIFIC COMPRESSOR SIZING INFORMATION, REFER TO TYLER APPLICATIONS FOR RACK SYSTEM COMPRESSORS AND/OR THE COMPRESSOR MANUFACTURERS FOR SINGLE COMPRESSORS. FOR LINE SIZING INFORMATION, REFER TO THE MISCELLANEOUS SECTION "BUFF" IN THE TYLER SPECIFICATION GUIDE.

Electrical Data:

Fans and Heaters (120 Volt)

MODEL	CASE LENGTH	FANS / CASE	TOTAL STANDARD FANS		TOTAL ECM FANS		TOTAL ANTI-SWEATS			
			AMPS	WATTS	AMPS	WATTS	DISCHARGE AIR		FRONT GLASS	
							AMPS	WATTS	AMPS	WATTS
N3HMHP	6'	2	1.06	96.0	0.64	34.0	0.10	12.0	N/A	N/A
N3HMHP	8'	2	1.06	96.0	0.64	34.0	0.13	15.6	N/A	N/A
N3HMHP	12'	3	1.59	144.0	0.96	51.0	0.20	24.0	N/A	N/A
N3HMGHP	6'	2	1.06	96.0	0.44	22.0	0.10	12.0	0.07	8.4
N3HMGHP	8'	2	1.06	96.0	0.44	22.0	0.13	15.6	0.09	10.8
N3HMGHP	12'	3	1.59	144.0	0.66	33.0	0.20	24.0	0.14	16.8

T-8 Lighting with Electronic Ballasts (120 Volt)

MODEL	CASE LENGTH	CANOPY LIGHTS* --- PER ROW				SHELF LIGHTS - PER ROW						MAXIMUM LIGHTING (5 ROWS)	
		AMPS		WATTS		AMPS			WATTS			AMPS	WATTS
		1	2	1	2	1	2	3	1	2	3		
N3HM(G)HP	6'	0.40	0.75	48	90	0.50	0.80	1.10	60	96	132	1.85	222
N3HM(G)HP	8'	0.50	0.95	60	114	0.70	1.10	1.40	84	132	168	2.35	282
N3HM(G)HP	12'	0.70	1.40	84	168	1.05	1.65	2.10	126	198	252	3.50	420

* Standard lighting for this case is 1 row of canopy lights.

Defrost Data:

DEFROST TYPE*	DEFROSTS PER DAY	DURATION TIME (MIN)**	ELEK. THERMOSTAT / AIR SENSOR SETTINGS			EPR SETTINGS ***		CONVENTIONAL COMPRESSOR SETTINGS****				DEFROST WATER (LB / FT / DAY)	
			USAGE	CUT IN	CUT OUT	R22 (PSIG)	R404A (PSIG)	R22 (PSIG)		R404A (PSIG)		N3HMHP	N3HMGHP
								CUT-IN	CUT-OUT	CUT-IN	CUT-OUT		
TIME OFF	6	28	MED TEMP	28°F	26°F	49	62	47	36	60	47	7.5	6.9

* All high performance cases use **OFF CYCLE** defrost.

** **NOTE:** 28 minutes is for EPR with suction stop for defrost isolation. Defrost times increases by six minutes (34 min. total) when defrost isolation is by pump down.

*** If EPR is utilized, use the settings shown in the chart. **NOTE:** The customer will need to set the EPR on the parallel rack or single unit to the appropriate suction temperature and the N3HM(G)HP cases must be on a separate suction stub with a separate EPR. **ADD 0.5#** to EPR setting for each 1000 foot rise in elevation.

**** Required setup for a conventional unit uses an electronic thermostat to assure accurate temperature control.

CASE-TO-CASE SUCTION LINE SUB-FEED BRANCH LINE SIZING												
MODEL	6'	8'	12'	16'	20'	24'	28'	32'	36'	40'	44'	48'
N3HM(G)HP / R22	1/2"	1/2"	5/8"	5/8"	7/8"	7/8"	7/8"	7/8"	7/8"	1 1/8"	1 1/8"	1 1/8"

CASE CIRCUITS: This case requires a 120V circuit for fans, lights and anti-sweat heaters.

Screens are standard. Shelving must be ordered separately. All rows of shelving require a shelf gasket. Shelves are available in 12", 15", 16", 18" and 20" deep sizes. When multiple shelf sizes are used, position smallest shelf size on top to largest shelf size on bottom.

UL SANITATION approved in accordance with ANSI/NSF – 7.

CASE BTUH REQUIREMENTS are calculated to produce approximately the indicated entering-air temperature with absolute maximum operating ambient limits of **75°F & 55RH**.

The information contained herein is based on technical analysis and/or tests performed in a controlled lab environment that are consistent with industry practices, and is intended as a reference for system sizing and configuration purposes only and for use by persons having technical skill at their own discretion and risk. Conditions of use are outside of Tyler's control and we do not assume and hereby disclaim any liability for results obtained or damages incurred through application of or reliance on the data presented, including but not limited to specific energy consumption with any particular model or installed application. SPECIFICATIONS ARE SUBJECT TO CHANGE WITHOUT NOTICE.

N3HMHP/N3HMGHP CROSS SECTION

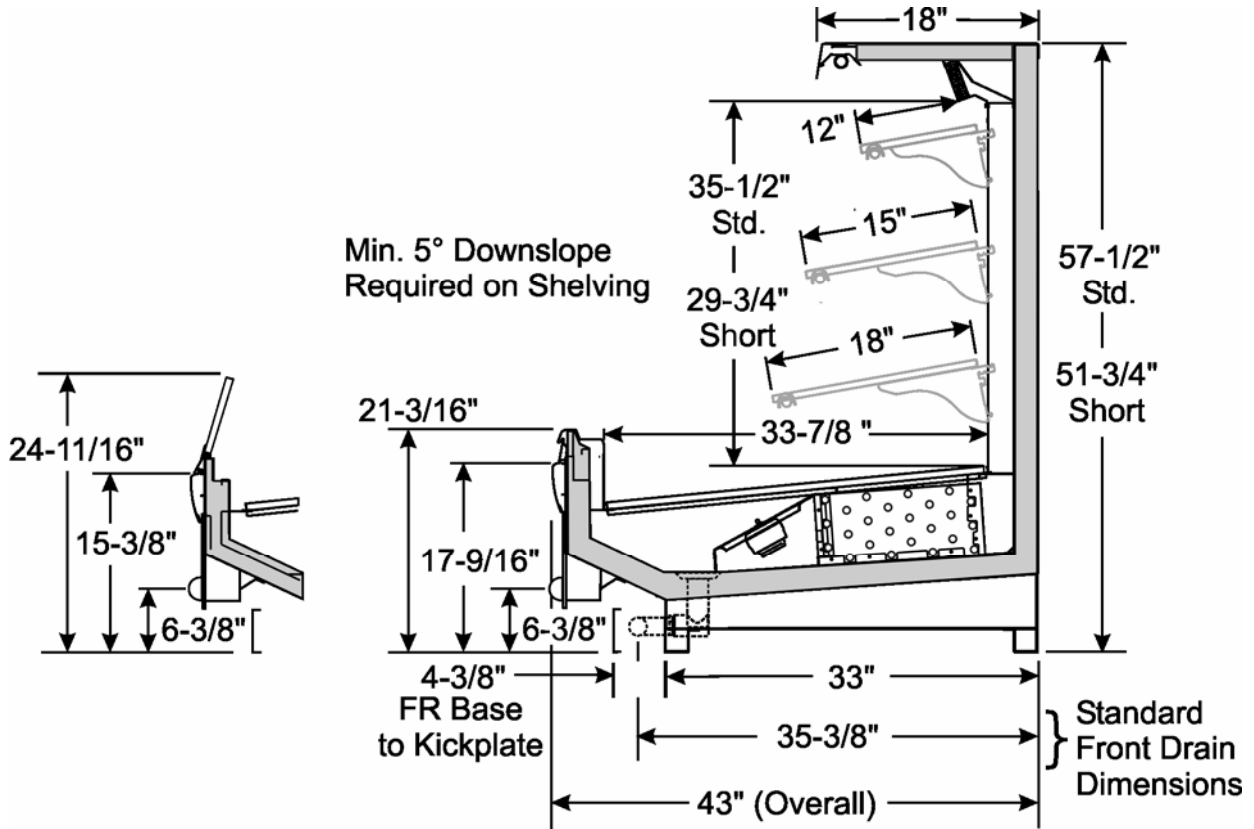

FLOOR PLAN

