

N3PL, N3PH

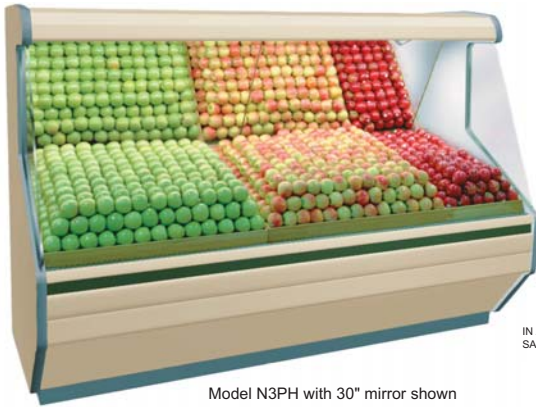

Model N3PH with 30" mirror shown



N3P merchandisers have an extended front that provides additional display capacity for bulk produce items. A standard 23" mirror creates a "waterfall" look to enhance product presentations. Use as a single-deck (see photo), or add optional shelving for more merchandising area.

Features & Benefits

- ♦ Energy-efficient copper tube and aluminum fin coils.
- ♦ One row of energy efficient T8 canopy lights with electronic ballasts provide appealing product illumination. Hinged light channel allows easy access to ballasts.
- ♦ Adjustable white powder-coated display screens and 23" mirror enhance product presentation.
- ♦ Solid steel base adds strength and durability.
- ♦ Easily removable front and top ducts enhance ease of sanitation.
- ♦ Hinged fan assembly allows access to coil and drain pan.
- ♦ Off-cycle defrost.

Options

- ♦ ECM fan motors for additional energy savings.
- ♦ Second row of T8 canopy lights and T8 shelf lighting with remote electronic ballasts provide greater product illumination.
- ♦ 16" or 30" mirrors enhance product presentation.
- ♦ Multiple-depth shelving alternatives.
- ♦ 3 or 6 position shelf brackets for varied shelf display angles.
- ♦ Step screens, fences, bag holders, water spray hoses, and scale hangers.

Specifications are subject to engineering changes without notice.

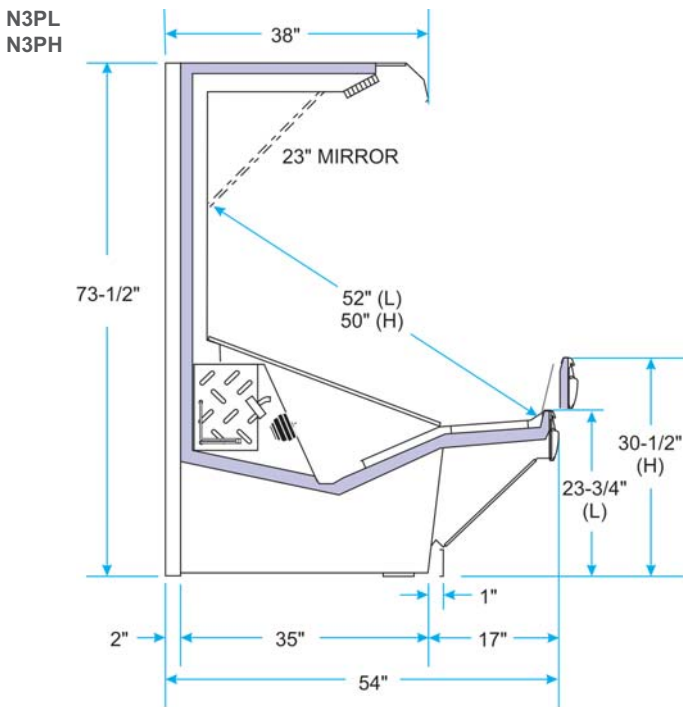

NOTE: N3PL front height is 30-3/4" to top of standard front fence.

Model	Case Length	Description	Capacity in Cubic Feet*
N3PL	8' • 12'	Waterfall w/ 23" Mirror & Low Front, standard coil	34.8 • 52.0
N3PH	8' • 12'	Waterfall w/ 23" Mirror & High Front, standard coil	33.5 • 50.0

* Cubic capacity is based on case with 23" mirror.

ALLOW 3" SPACE between the back of this case and the store wall, other cases or coolers to minimize possible condensation problems. FORCED VENTILATION may be necessary in some situations.

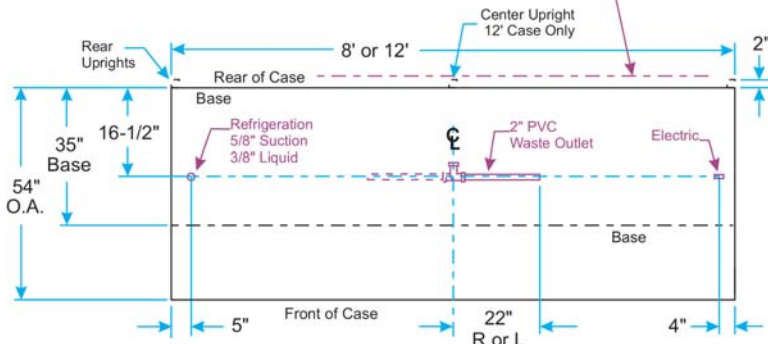

Optional Accessories

Add 1-1/2" for Standard Patch End



Mirrors in a variety of sizes provide the perfect display appearance to showcase your bulk produce in an appealing and inviting manner.



This spray hose assembly allows manual misting of bulk produce that keeps products looking fresh.