

TYLER

REFRIGERATION



Carrier

A United Technologies Company

A^{series} Advantage

Installation & Service Manual

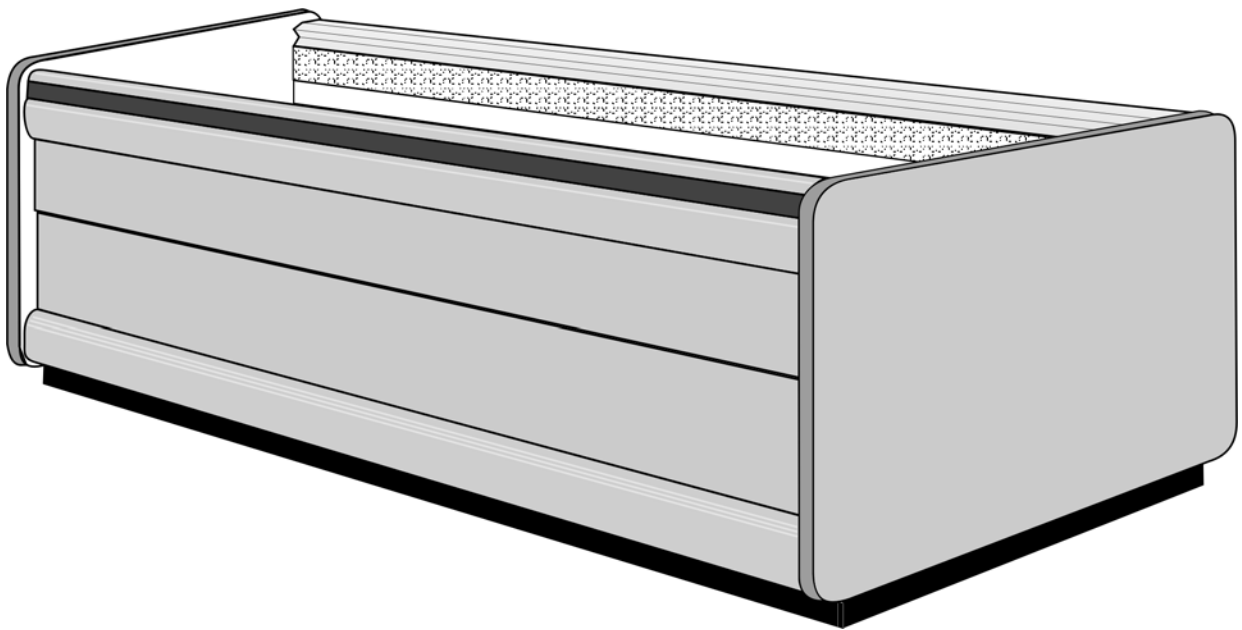

NFX, NFSX, NCSX, NFSGX, NCSGX

OPEN WELL FROZEN FOOD & ICE CREAM MERCHANDISERS
Low Temperature Self Serve Display Cases

**This manual has been designed to be used in conjunction with the General
(UL/NSF) Installation & Service Manual.**

Save the Instructions in Both Manuals for Future Reference!!

This merchandiser conforms to the American National Standard Institute & NSF International Health and Sanitation standard ANSI/NSF 7 - 2003.

PRINTED IN IN U.S.A.	Specifications subject to change without notice.	REPLACES EDITION	1/06	ISSUE DATE	11/07	PART NO.	9037163	REV. C
-------------------------	---	---------------------	------	---------------	-------	-------------	---------	--------

CONTENTS

	<u>Page</u>
Specifications	
NFX/NFSX/NCSX/NFSGX/NCSGX Specification Sheets	4
Line Sizing Requirements (See General-UL/NSF I&S Manual)	
Pre-Installation Responsibilities (See General-UL/NSF I&S Manual)	
Installation Procedures	
Carpentry Procedures	7
Case Pull-Up Locations	7
1" Solid Partition	7
Plexiglas Partition	7
Trim Installation/Alignment	7
Plumbing Procedures (See General-UL/NSF I&S Manual)	
Refrigeration Procedures	7
Optional Dual Temperature Control	7
Electrical Procedures	8
Electrical Considerations	8
Defrost Information	8
Defrost Control Chart	8
Installation Procedure Check Lists (See General-UL/NSF I&S Man.)	
Wiring Diagrams	8
NFX/NFSX/NCSX/NFSGX/NCSGX	
Domestic & Export (50 Hz) Case Circuits	9
Dual Temperature Control Circuits	11
Cleaning and Sanitation (See General-UL/NSF I&S Manual)	
Component Removal and Installation Instructions for Cleaning 13	
Bottom Trays	13
NSF Product Thermometer	13
Discharge Air Honeycomb	13
Rear Riser Panels	13
Front Air Duct Panels	13
Rear Riser Canopy Cover	13
Front Cladding	13

	<u>Page</u>
Service Instructions	
Preventive Maintenance (See General-UL/NSF I&S Manual)	
Fan Blade and Motor Replacement (See Gen.-UL/NSF I&S Manual)	
Color Band and Bumper Replacement (See Gen.-UL/NSF I&S Man.)	
NSF Product Thermometer Replacement	14
Defrost Heater Replacement	14
Anti-Sweat Replacement	15
Front Glass Replacement (NFSGX/NCSGX)	15
Parts Information	
Cladding and Optional Trim Parts List	16
Operational Parts List	18
TYLER Warranty (See General-UL/NSF I&S Manual)	

The following Low Temperature Open Well Frozen Food and Ice Cream Merchandiser models are covered in this manual:

MODEL	DESCRIPTION
NFX/NFSX	8' & 12' OPEN WELL FROZEN FOOD MERCHANDISER
NCSX	8' & 12' OPEN WELL ICE CREAM MERCHANDISER
NFSGX	8' & 12' GLASS FRONT OPEN WELL FROZEN FOOD MERCHANDISER
NCSGX	8' & 12' GLASS FRONT OPEN WELL ICE CREAM MERCHANDISER

SPECIFICATIONS

NFX/NFSX/NCSX/NFSGX/NCSGX Open Well FF & IC Merchandisers

Refrigeration Data:

MODEL	CASE LENGTH	CASE USAGE	CAPACITY (BTUH / FT)		EVAPORATOR (°F)	UNIT SIZING (°F)	DISCHARGE AIR		AVG. REF. CHARGE (LBS/FT)
			PARALLEL	CONVENTIONAL			TEMPERATURE (°F)	VELOCITY (FPM)	
NFX/NFSX	8'/12'	FROZEN FOOD	313*	327*	-25**	-28	-15	200***	0.28****
NCSX	8'/12'	ICE CREAM	390*	400*	-35**	-38	-25	200***	0.28****
NFX/NFSX	8'/12'	MED TEMP	314*	322*	+15**	+13	+22	200***	0.28****
NFSGX	8'/12'	FROZEN FOOD	366*	382*	-25**	-28	-15	200***	0.28****
NCSGX	8'/12'	ICE CREAM	458*	470*	-35**	-38	-25	200***	0.28****
NFSGX	8'/12'	MED TEMP	367*	376*	+15**	+13	+22	200***	0.28****

* For sizing all refrigeration equipment other than TYLER, use conventional BTUH values.

** Evaporator temperature is based on the saturated pressure leaving the case.

*** Air velocity measured 1 hour after defrost at the discharge air duct using an ALNOR JR. velometer with a scoop.

**** This is an average refrigeration charge per foot based on R22 and R404A refrigerant usage.

FOR SPECIFIC COMPRESSOR SIZING INFORMATION, REFER TO TYLER APPLICATIONS FOR RACK SYSTEM COMPRESSORS AND/OR THE COMPRESSOR MANUFACTURERS FOR SINGLE COMPRESSORS. FOR LINE SIZING INFORMATION, REFER TO THE MISCELLANEOUS SECTION "BUFF" IN THE TYLER SPECIFICATION GUIDE.

Electrical Data:

Fans and T-8 Lighting with Electronic Ballasts (120 Volt)

MODEL	CASE LENGTH	FANS / CASE	TOTAL STD FANS		TOTAL ECM FANS		TOTAL T-8 LIGHTING (PER ROW)			
			AMPS	WATTS	AMPS	WATTS	REAR SHELF LIGHT		OPT. SUPRSTR. LIGHT	
NFX	8'	2	0.68	60.4	0.44	22.0	N/A	N/A	0.50	60.0
NFSX/NCSX/ NFSGX/ NCSGX	8'	2	0.68	60.4	0.44	22.0	0.50	60.0	0.50	60.0
NFX	12'	3	1.02	90.6	0.66	33.0	N/A	N/A	0.70	84.0
NFSX/NCSX/ NFSGX/ NCSGX	12'	3	1.02	60.6	0.66	33.0	0.70	84.0	0.70	84.0

NOTE: Optional shelving superstructures with lights have same electrical requirements per row of lights as shown in this chart. A separate electrical supply for superstructure lights must be provided since there is no plug in from the superstructure to the case.

Heaters (120 and 208 Volt)

MODEL	CASE LENGTH	TOTAL ANTI-SWEAT HEATERS (120 V)						GLASS RETAINER		HEATED GLASS (120 V)		DEFROST HEATER (208 V)	
		DISCHARGE AIR		REAR SHELF (W/ LIGHT)		REAR SHELF (W/O LIGHT)		AMPS	WATTS	AMPS	WATTS	AMPS	WATTS
NFX	8'	0.95	114.0	N/A	N/A	N/A	N/A	N/A	N/A	N/A	N/A	6.9	1,435
NFSX	8'	N/A	N/A	1.25	150.0	2.20	264.0	N/A	N/A	N/A	N/A	6.9	1,435
NCSX	8'	N/A	N/A	1.25	150.0	2.20	264.0	N/A	N/A	N/A	N/A	13.8	2,870
NFSGX	8'	N/A	N/A	1.25	150.0	2.20	264.0	0.94	113.0	0.66	79.0	6.9	1,435
NCSGX	8'	N/A	N/A	1.25	150.0	2.20	264.0	0.94	113.0	0.66	79.0	13.8	2,870
NFX	12'	1.26	152.0	N/A	N/A	N/A	N/A	N/A	N/A	N/A	N/A	10.3	2,142
NFSX	12'	N/A	N/A	1.70	206.0	2.95	358.0	N/A	N/A	N/A	N/A	10.3	2,142
NCSX	12'	N/A	N/A	1.70	206.0	2.95	358.0	N/A	N/A	N/A	N/A	20.6	4,285
NFSGX	12'	N/A	N/A	1.70	206.0	2.95	358.0	1.25	150.0	1.55	186.0	10.3	2,142
NCSGX	12'	N/A	N/A	1.70	206.0	2.95	358.0	1.25	150.0	1.55	186.0	20.6	4,285

CASE CIRCUITS: In addition to the 208V defrost circuit, there is the 120V case fan circuit plus the 120V case anti-sweat heater circuit. Shelf or canopy lights require a separate 120V circuit which can be switched at the back room for convenience in controlling the lights.

UL SANITATION approved in accordance with ANSI/NSF - 7.

CASE BTUH REQUIREMENTS are calculated to produce approximately the indicated entering-air temperature with absolute maximum operating ambient limits of 75°F & 55RH.

The information contained herein is based on technical analysis and/or tests performed in a controlled lab environment that are consistent with industry practices, and is intended as a reference for system sizing and configuration purposes only and for use by persons having technical skill at their own discretion and risk. Conditions of use are outside of Tyler's control and we do not assume and hereby disclaim any liability for results obtained or damages incurred through application of or reliance on the data presented, including but not limited to specific energy consumption with any particular model or installed application. SPECIFICATIONS ARE SUBJECT TO CHANGE WITHOUT NOTICE.

208 VOLT DEFROST (AMPS)														
FT	8	12	16	20	24	28	32	36	40	44	48	52	56	60
FF/MED 1 PH	6.9 TG-30	10.3 TG-30	13.8 TG-30	17.2 TG-30	20.6 TG-30	24.1 TG-40	27.5 TG-40	30.9 TG-40	34.3 TG-50	37.8 TG-50	41.2 TG-50	44.6 TG-50	N/A	N/A
FF/MED 3 PH	N/A	N/A	12.0 TG-3-30	15.0 TG-3-30	18.0 TG-3-30	15.0 TG-3-30	18.0 TG-3-30	18.0 TG-3-30	21.0 TG-3-30	25.0 TG-3-40	28.0 TG-3-40	30.0 TG-3-40	33.0 TG-3-50	36.0 TG-3-50
IC 1 PH	13.8 TG-30	20.6 TG-30	27.6 TG-40	34.4 TG-50	41.2 TG-50	(Separate circuit recommended due to high amp draw) N/A								
IC 3 PH	N/A	N/A	42.0 TG-3-40	30.0 TG-3-40	36.0 TG-3-50	30.0 TG-3-40	36.0 TG-3-50	36.0 TG-3-50	43.0 TG-3-50	30/36 TG-3-50-50	36/36 TG-3-50-50	36/30 TG-3-50-50	36/36 TG-3-50-50	36/36 TG-3-50-50
CASE-TO-CASE SUCTION LINE SUB-FEED BRANCH LINE SIZING														
R404A FF	5/8"	7/8"	7/8"	7/8"	7/8"	7/8"	1 1/8"	1 1/8"	1 1/8"	1 1/8"	1 1/8"	1 1/8"	1 3/8"	1 3/8"
R22 MED	5/8"	7/8"	7/8"	7/8"	7/8"	7/8"	1 1/8"	1 1/8"	1 1/8"	1 1/8"	1 1/8"	1 1/8"	1 3/8"	1 3/8"
R404A IC	7/8"	7/8"	7/8"	1 1/8"	1 1/8"	1 1/8"	1 1/8"	1 1/8"	1 3/8"	1 3/8"	1 3/8"	1 3/8"	1 3/8"	1 3/8"

Defrost Data:

DEFROST TYPE*	DEFROSTS PER DAY	DURATION TIME (MIN)	TERMINATION (°F)	EPR SETTINGS **		DEFROST WATER (LB / FT / DAY)
				R22 (PSIG)	R404A (PSIG)	
ELECTRIC / FF	1	60	50	7.4	14	N/A
ELECTRIC / IC	1	36	50	2.6	8.1	N/A
ELECTRIC / MED	1	36	50	37	49.5	N/A
HOT GAS / FF	2-3	20-25	55*	7.4	14	N/A
HOT GAS / IC	1	25-30	55*	2.6	8.1	N/A
HOT GAS / MED	2-3	16-20	55*	37	49.5	N/A

* If an Electronic Sensor is used for termination, it should be set at 70°F termination temperature. The sensor must be located in the same location as the defrost termination klixon for that defrost type.

** Set EPR to give this pressure at the case.

**NFX CROSS SECTION
With Optional DSAL Superstructure**

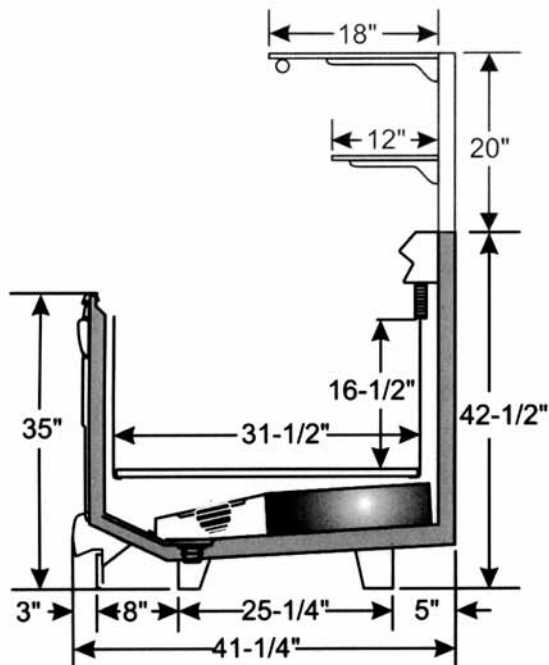

**NFSX/NCSX CROSS SECTION
With Optional DNS Superstructure**

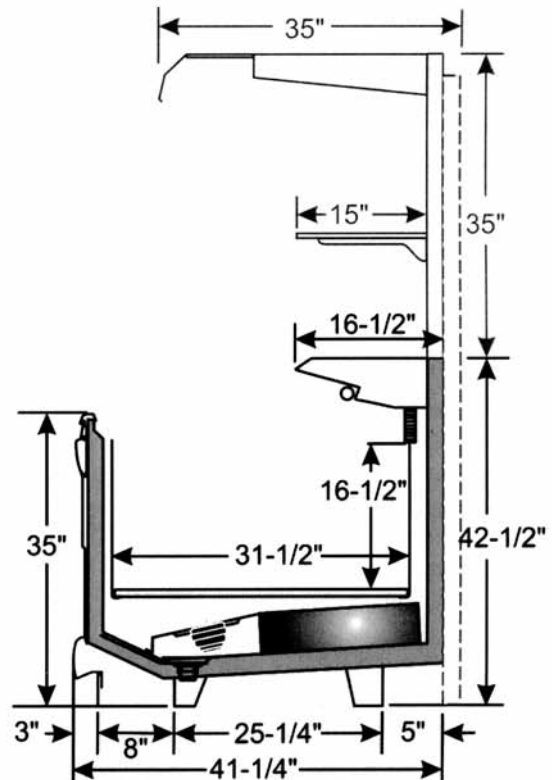

NFSGX/NCSGX CROSS SECTION

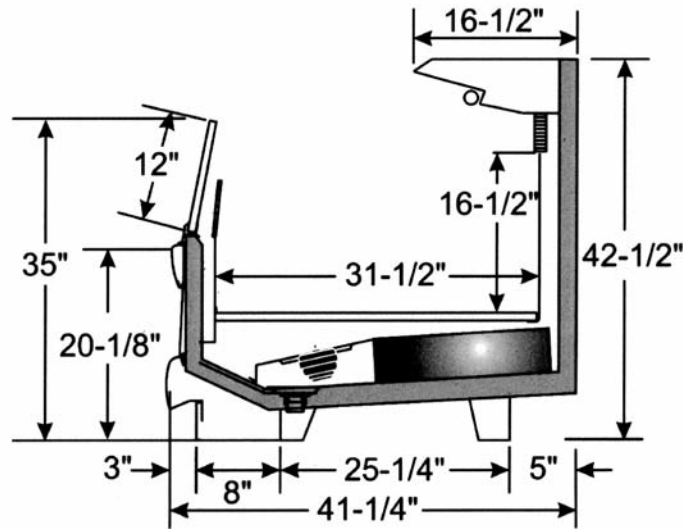

NFX/NF(C)SX/NF(C)SGX FLOOR PLAN

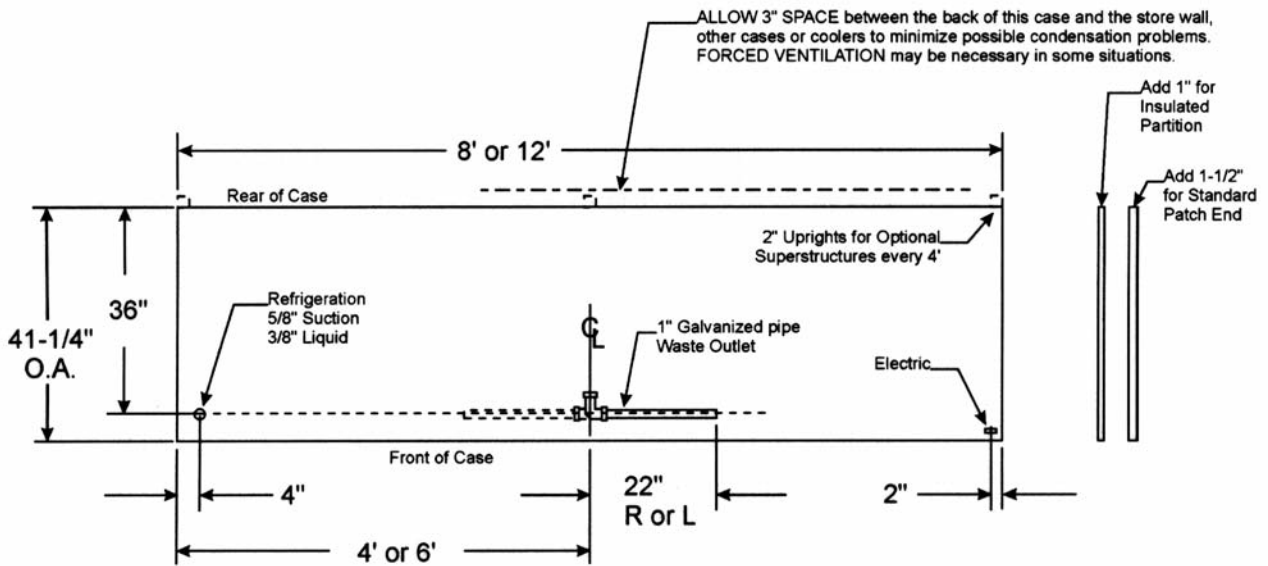

INSTALLATION PROCEDURES

Carpentry Procedures

Case Pull-Up Locations

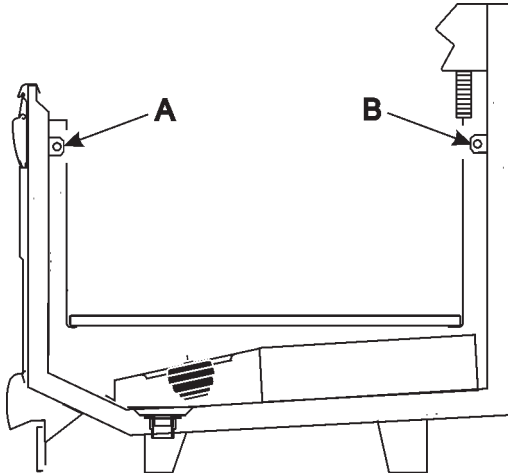

The NFX/NFSX/NCSX/NFSGX and NCSGX models have two pull-ups at each end of the case. Pull-ups A and B are located as shown and used for joining all cases.

1" Solid Partition

A 1" insulated partition is required between adjacent gas defrost cases that are on different refrigeration systems. 1" partitions are shipped installed as specified in the case order. Make sure the partitioned case is being installed in the proper location in the case line-up. This assures proper refrigeration to all parts of the case line-up.

Apply sealant to outside surface of partition where the two surfaces of the adjoining case will contact the partition.

See "General-UL/NSF I&S Manual" for line-up assembly instructions.

After all case pull-ups have been secured, all interior wall joint seams should be sealed with duct tape.

Plexiglas Partition

A plexiglas plug partition is required on adjacent electric defrost cases that are on different refrigeration systems. These partitions can be installed after the cases have been joined.

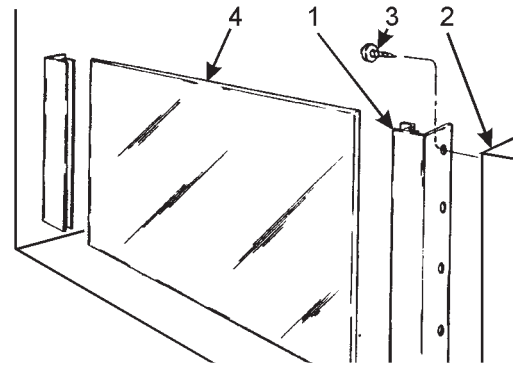

1. Install partition brackets (1) at case joint on front, center and/or rear case wall (2) with screws (3)
2. Slide plexiglas partitions (4) into partition brackets (1).

Trim Installation/Alignment

See "General-UL/NSF I&S Manual" for bumper, color band, raceway and kickplate installation.

Refrigeration Procedures

See "General-UL/NSF I&S Manual" for general system, control and superheat information.

Optional Dual Temperature Control

The dual temperature control unit is a factory installed option. This control allows the user to easily switch from medium to low temperature operation by flipping a switch. The dual temperature control consists of an EPR valve in the suction line coming off the evaporator. The EPR valve can be bypassed with a solenoid controlled bypass line around it. The toggle switch opens or closes this solenoid.

When the solenoid is open, the evaporator is connected directly to the compressor suction that allows for low temperature operation. When the solenoid is closed, the evaporator must operate through the EPR valve which has been preset to the desired medium temperature.

EXAMPLE: R-404A system with 12 psig of suction pressure. With the suction line solenoid open, the coil pressure operates at 12 psig with a temperature of -29°F. When the

toggle switch is flipped, the solenoid closes directing the flow through the EPR valve. If the EPR valve is set for 48 psig, the evaporator will see a coil temperature of 12°F and will operate at a discharge air temperature of about 22°F.

When gas defrost is used, an additional check valve is mounted around the EPR valve to allow reverse flow for the defrosting gas. A fan delay is also connected with gas defrost to cycle the fans off, but only during the medium temperature mode.

Electrical Procedures

Electrical Considerations

CAUTION

Make sure all electrical connections are tight. This prevents burning of electrical terminals and/or premature component failure.

NOTE

The raceway houses the electrical wiring and components for the case. All raceway covers will be shipped loose.

Case Fan Circuit

This circuit is to be supplied by an uninterrupted, protected 120V circuit. The case fan circuit is not cycled, except when equipped for gas defrost. On gas defrost cases the fan circuit is controlled by a 50/40 klixon when used for medium temperatures.

NOTE

With gas defrost, the fans will not start until the coil temperature reaches 40°F at the fan delay klixon.

Anti-Sweat Circuit

All cases have at least one anti-sweat heater in each discharge air grid and return air grid. Cases with front glass have an additional anti-sweat heater under the glass retainer. Anti-sweat heaters are wired directly to the main power supply so they can operate at all times.

Defrost Information

See “General-UL/NSF I&S Manual” for operational descriptions for each type of defrost control.

Defrost Control Chart

NFX/NFS(G)X/NCS(G)X

Defrost Type	Defrosts Per Day	Defrost	
		Duration (Min)	Term. Temp.
Electric/FF	1	60	50°F
Elec/IC/MED	1	36	50°F
Gas/FF	2-3	20-25	55°F
Gas/IC	1	25-30	55°F
Gas/MED	2-3	16-20	55°F

Most klixons are located on the end of the evaporator coil. Klixon uses are as follows: Electric Defrost Termination, Electric Defrost Failsafe (Opt.), Gas Defrost Fan Delay (Dual Temp) and Glass Anti-Sweat (Dual Temp).

NOTE

The defrost termination klixon for gas defrost is located at the bypass check valve.

CAUTION

If electronic sensors are used in place of the klixons, the sensors must be located in the same location as the klixons for that defrost type. Any other locations will effect the refrigeration efficiency of the case.

WIRING DIAGRAMS

ELECTRICIAN NOTE - OVERCURRENT PROTECTION

120V circuits should be protected by 15 or 20 Amp devices per the requirements noted on the cabinet nameplate or the National Electrical Code, Canadian Electrical Code - Part 1, Section 28. 208V defrost circuits employ No. 12 AWG field wire leads for field connections. On remote cases intended for end to end line-ups, bonding for ground may rely upon the pull-up bolts.

The following wiring diagrams on pages 9 thru 11 will cover the NFX/NFSX/NCSX/NFSGX/NCSGX case circuits and dual temp circuits with electric and hot gas defrost options.

NFX/NFSX/NCSX/NFSGX/NCSGX Domestic & Export (50 Hz) Case Circuits



1. THE USER SHALL BE RESPONSIBLE FOR OBTAINING ALL NECESSARY PERMITS AND APPROVALS TO THE INSTALLATION OF THIS EQUIPMENT.
2. INFORMATION IS FOR ENGINEERING USE ONLY.
3. ALL DIMENSIONS ARE IN INCHES UNLESS OTHERWISE SPECIFIED.
4. DIMENSIONS APPLY TO FINISHED PART AFTER POLISHING.
5. NO UNUSUAL REVISIONS ALLOWED.

NOTE: 3 LAMPS FOR 12FT CASES ARE SHOWN.
2 LAMPS AND A TWO LAMP BALLAST
ARE USED IN 8FT CASES.

OPTIONAL T8 CANOPY LIGHTING

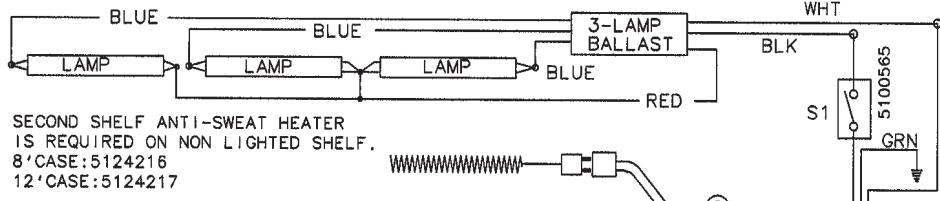

SECOND SHELF ANTI-SWEAT HEATER
IS REQUIRED ON NON LIGHTED SHELF.
8' CASE: 5124216
12' CASE: 5124217

OPTIONAL SHELF ANTI-SWEAT HEATER
8' CASE: 5124818
12' CASE: 5124819

SHELF WIRING

REAR RISER NOSE
ANTI-SWEAT HEATER
8' CASE: 5124818
12' CASE: 5124819

LEFT END HEATED
GLASS PANEL

5129895

RIGHT END HEATED GLASS PANEL

5129895

GLASS RETAINER HEATER
8' CASE: 5218331
12' CASE: 5218332

ANTI-SWEAT HEATER CONNECTIONS

DEFROST HEATER

DEFROST LIMIT THERMOSTAT
(OPENS 50°F, CLOSES 30°F)

SECOND DEFROST HEATER IS
STANDARD IN NCSGX CASES.

8' CASE: 5199414
12' CASE: 5199415

OPTIONAL
SOLENOID
VALVE



FAN MOTORS: (3) PER 12FT, (2) PER 8FT CASES

CASE WALL

TO FANS POWER SUPPLY

OPTIONAL CASE
TEMPERATURE
THERMOSTAT

208VAC 60HZ
SUPPLY
OR
220VAC 50HZ
INTERNATIONAL

120VAC 60HZ
SUPPLY
OR
220VAC 50HZ
INTERNATIONAL

NOTE: ALL CASES MUST BE GROUNDED

REV	DESCRIPTION	DATE	BY	CHK	APP
1	CHANGED THE BORDER AND REMOVED THE 5123836 FAN STUB HARNESS	220C107	GXH	LC	CK
2	DECIMALS +/- .030 ANGLES +/- 1 DEG	30JUL97	NONE	NONE	NONE
DIAGRAM WRG ELEC DFR NFX NFS(G)X NCS(G)X					
9028666					F

1. TYLER REFRIGERATION OBTAINS RIGHTS IN PATENTS AND TRADEMARKS. INFORMATION IS FOR GUIDANCE ONLY AND MAY NOT BE USED WITHOUT PERMISSION. 2. SPECIFICATIONS ARE IN INCHES UNLESS OTHERWISE SPECIFIED. 3. ALL TREATMENT TO FINISHED PART AFTER ANNEALING. 4. ALL TREATMENT TO FINISHED PART AFTER ANNEALING. 5. NO MANUAL REVISIONS ALLOWED.

(F) SECOND ANTI-SWEAT HEATER REQUIRED ON NON-LIGHTED SHELF

(F) OPTIONAL SHELF ANTI-SWEAT HEATER

REAR RISER NOSE ANTI-SWEAT HEATER

REAR RISER ANTI-SWEAT HEATER CONNECTIONS

(L) OPTIONAL SUPERSTRUCTURE LIGHTING POWER HARNESS CONNECTION. (SEE INSTALLATION MANUAL FOR SUPER STRUCTURE WIRING.)

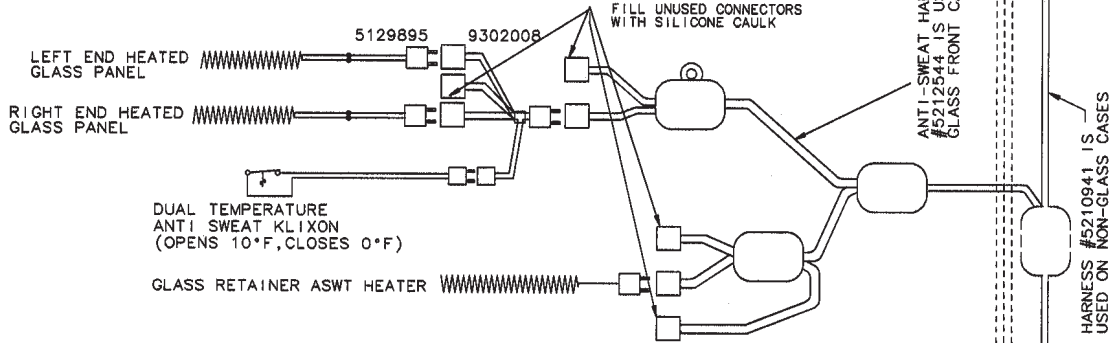

ANTI-SWEAT HEATER CONNECTIONS FOR GLASS FRONT CASES.

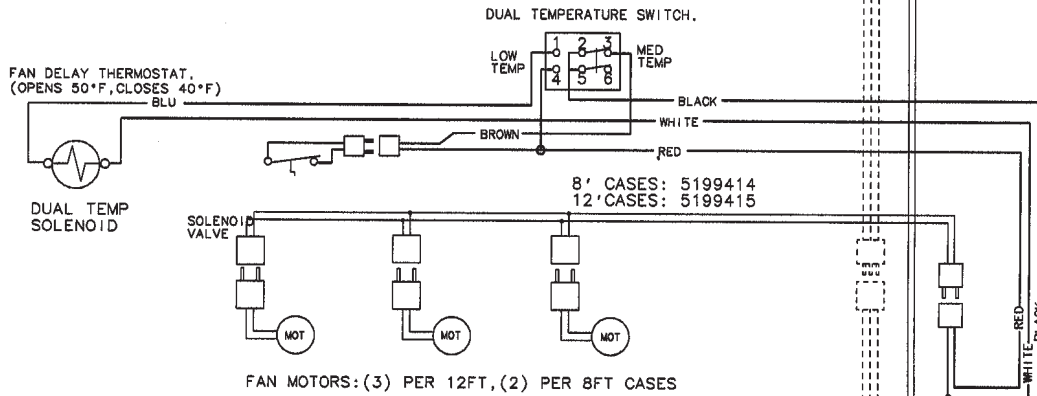

FAN MOTORS: (3) PER 12FT, (2) PER 8FT CASES

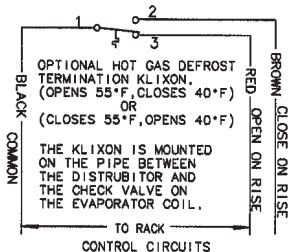

OPTIONAL HOT GAS DEFOST TERMINATION KLIXON. (OPENS 55°F, CLOSES 40°F) OR (CLOSES 55°F, OPENS 40°F)

THE KLIXON IS MOUNTED ON THE PIPE BETWEEN THE DISTRIBUTOR AND THE CHECK VALVE ON THE EVAPORATOR COIL.

CONTROL CIRCUITS

FILL THE UNUSED CONNECTOR WITH SILICON CAULK

CASE WALL

FAN PANEL GROUND

GRN

GRN

BLK

WHT

BLK

WHT

WHT

120VAC 60HZ OR 220VAC 60HZ SUPPLY

FIELD END

5199320

9023594

BLACK

WHITE

RED

GRN

BLK

WHT

BLK

WHT

BLK

WHT

BLK

WHT

BLK

WHT

BLK

WHT

BLK

WHT

BLK

WHT

BLK

WHT

BLK

WHT

REV	DESCRIPTION	DATE	BY	CHK
F	REMOVED THE ELEC DFR PORTION AND CHANGED THE BORDER	17OCT07 6XH	50004	
REV	DESCRIPTION	DATE	BY	CHK
1		15OCT96	LC	
2		96-104	CK	
3				
4				
5				
6				
7				
8				
9				
10				
11				
12				
13				
14				
15				
16				
17				
18				
19				
20				
21				
22				
23				
24				
25				
26				
27				
28				
29				
30				
31				
32				
33				
34				
35				
36				
37				
38				
39				
40				
41				
42				
43				
44				
45				
46				
47				
48				
49				
50				
51				
52				
53				
54				
55				
56				
57				
58				
59				
60				
61				
62				
63				
64				
65				
66				
67				
68				
69				
70				
71				
72				
73				
74				
75				
76				
77				
78				
79				
80				
81				
82				
83				
84				
85				
86				
87				
88				
89				
90				
91				
92				
93				
94				
95				
96				
97				
98				
99				
100				

ALSO APPLIES TO 8&12FT: NFX, NFS(G)X, NCS(G)X, NFN(G)X, NFW(G)X, NCBX, NCR(G)X, NCF(G)X, NCF(G)X, NCBX

NOTE: ALL CASES MUST BE GROUNDED

CLEANING AND SANITATION

Component Removal and Installation Instructions for Cleaning

Bottom Trays

1. Remove product from bottom of case.
2. Grasp and lift out each of the bottom trays from the case interior and carefully remove through the door openings
3. After cleaning, replace in reverse order.

NSF Product Thermometer

Remove four screws and product thermometer bracket assembly from right rear location in the case. After cleaning, replace product thermometer bracket assembly and secure with four screws.

Discharge Air Honeycomb

1. Remove screws and bottom retainer strip from front or rear interior of case.

NOTE

Note position of the honeycomb grid during removal so it can be reinstalled the same way.

2. Remove honeycomb grid sections from the front or rear duct.

CAUTION

Improper installation of the honeycomb grid section could result in improper air flow and/or poor refrigeration.

3. After cleaning, replace honeycomb grid sections as they were removed and secure with the bottom retainer strip and screws.

Rear Duct Panels

1. Remove bottom trays and discharge air honeycomb, see this page.
2. Remove mounting screws from rear duct panel.
3. After cleaning, replace in reverse order.

Front Air Duct Panels

1. Remove bottom trays, see this page.
2. Remove screws and front air duct panels from case.
3. After cleaning, replace in reverse order.

Rear Riser Canopy Cover (NFSX/NCSX/NFSGX/NCSGX)

1. Remove screws and rear riser joint trim.
2. Remove screws, price tag molding and rear riser canopy cover from top of case.
3. After cleaning, replace rear riser canopy cover and remaining components in reverse order.

Front Cladding

1. Remove front kickplate and raceway cover.
2. Remove screws from bottom and top of front cladding and pull cladding down to remove it from behind the bottom edge of the bumper retainer.
3. After cleaning, replace front cladding and remaining front components in reverse order.

SERVICE INSTRUCTIONS

See “General-UL/NSF I&S Manual” for fan blade and motor replacement, color band and bumper replacement and raceway cover removal instructions.

NSF Product Thermometer Replacement

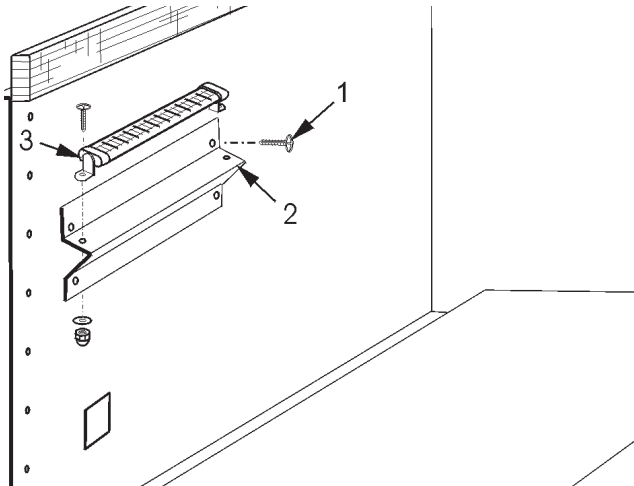

1. Remove four screws (1) and thermometer bracket (2) from rear of case.
2. Remove two screws, nuts, washers and the product thermometer (3) from the thermometer bracket (2).
3. Install and secure a new product thermometer (3) on the thermometer bracket (2) with two screws, washers and nuts.
4. Install thermometer bracket (2) on rear of case with four screws (1).

Defrost Heater Replacement

WARNING

Always shut off electricity to case before replacing a defrost heater. Automatic cycling of fans or electrical power to wire ends could cause personal injury and/or death.

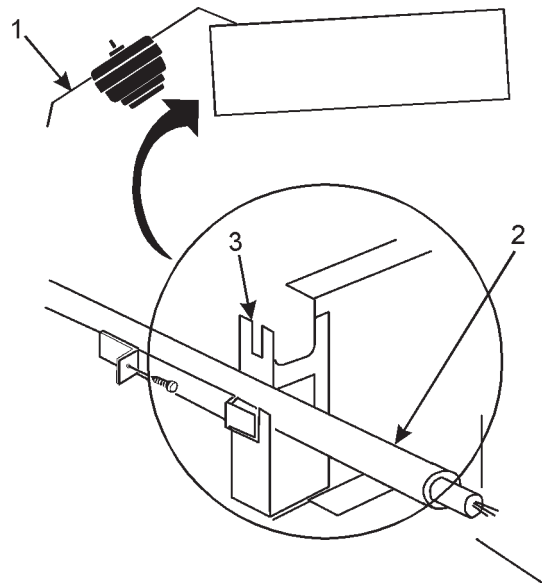

1. Remove bottom trays from case.
2. Unclip and lift up fan plenum (1).
3. Disconnect defective defrost heater (2) and remove from mounting clips (3) and case.
4. Install new defrost heater (4) in reverse order.
5. Restore electrical power to case.

Anti-Sweat Replacement

WARNING

Shut off or disconnect power supply to case before changing an anti-sweat. Electrical power from wire ends could damage other components and/or cause personal injury or death.

Discharge Air Grid Anti-Sweat (NFX Only)

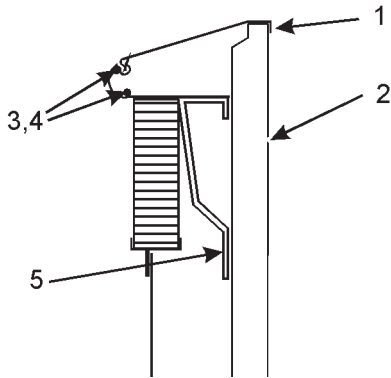

1. Remove screws and rear guard trim (1) from top of rear case wall (2).
2. Disconnect or cut the defective anti-sweat wire (3) from the case wires.
3. Remove and replace the aluminum tape (4) and defective anti-sweat wire (3) from top of rail and wire trim assembly (5).
4. Reconnect anti-sweat wires to case wires. Reinstall rear guard trim (1) and secure with screws.

Canopy Anti-Sweat Locations (NFSX/NCSX/NFSGX/NCSGX)

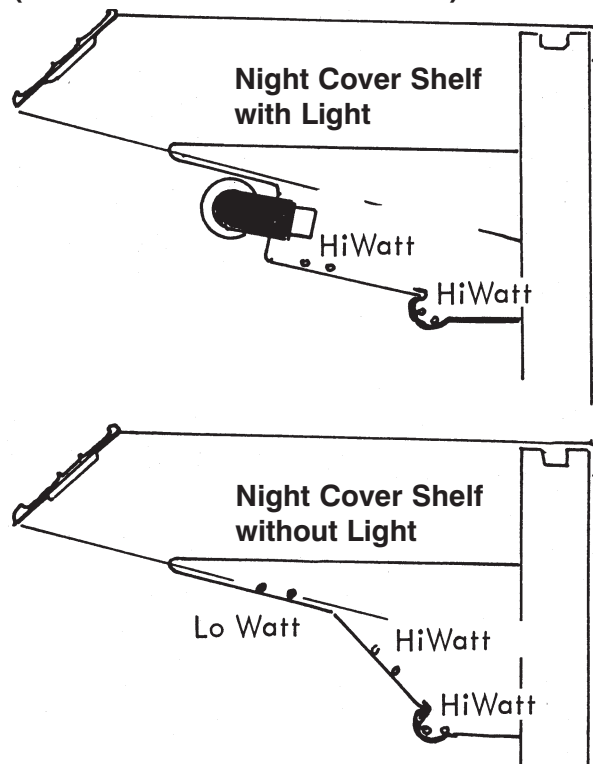

Front Glass Replacement (NFSGX/NCSGX)

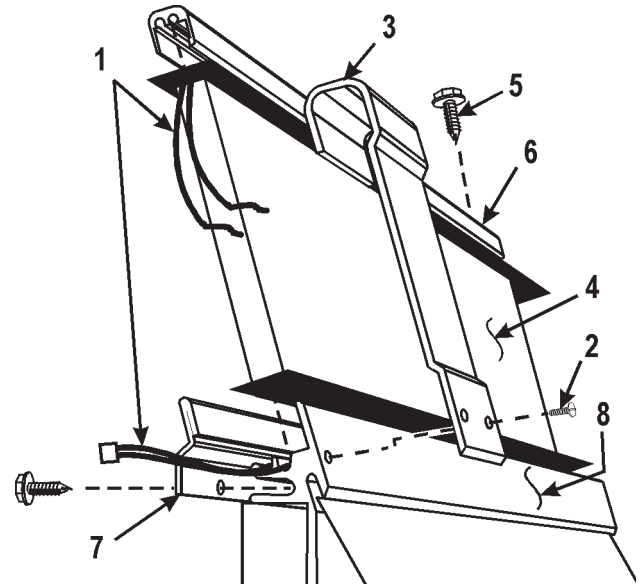

1. Unplug or disconnect heated glass panels and glass retainer anti-sweat wires (1).
2. Remove two screws (2) and glass joint trim (3) from both joints of the broken glass (4).
3. Remove screws (5) and glass trim rail (6) from top of glass (4).
4. Loosen rear retainer (7) and remove broken glass (4) from glass retainer assembly (8).

NOTE

Inspect the anti-sweat wire in glass retainer assembly. If wire is damaged or broken, replace it before replacing the front glass.

5. Apply sealant tape to top and bottom edge of new glass (4).
6. Position new glass (4) in glass retainer assembly (8) and secure by tightening rear retainer (7).
7. Install glass trim rail (7) with screws (6) over top edge of new glass (4).
8. Install glass joint trim (3) with two screws (2) over the joint areas of glass (4).
9. Reconnect heated glass panels and glass retainer anti-sweat wires (1).

PARTS INFORMATION

Cladding and Optional Trim Parts List

Item Description	NFX, NFSX, NCSX, NFSGX and NCSGX	
	8'	12'
1 Screw (NFX)	5205439 (4)	5205439 (4)
2 Lower Rear Riser Joint Trim (NFX)	5182434	5182434
3 Top Rear Riser Joint Trim (NFX)	5629361	5629361
4 Screw (NFX)	5058099 (4)	5058099 (4)
5 Screw (NFS(G)X/NCS(G)X)	5058099 (4)	5058099 (4)
6 Top Shelf Joint Trim (NFS(G)X/NCS(G)X)	5629360	5629360
7 Lower Top Shelf Joint Trim without light)(NFS(G)X/NCS(G)X)	5182435	5182435
8 Screw (NFS(G)X/NCS(G)X)	5205439 (4)	5205439 (4)
9 Screw (NFS(G)X/NCS(G)X)	5205439 (2)	5205439 (2)
10 Lower Top Shelf Joint Trim (with light)(NFS(G)X/NCS(G)X)	5128761	5128761
11 Screw	5145037 (4)	5105037 (4)
12 Return Air Duct Joint Trim	5203017	5203017
13 Hand Rail Backer	9025316	9025316
14 Color Band Backer, Ptd. (NFX/NFSX/NCSX)	9040223	9040223
15 Bumper Backer	---- color per order ----	
16 Horizontal Joint Trim	5127503	5127503
17 Cladding Retainer	9300197 (4)	9300197 (4)
Screw	5183536 (8)	5183536 (8)
18 Raceway Cover Backer	---- color per order ----	
19 Raceway	9300218	9300219
Screw	5183536 (18)	5183536 (18)
Kickplate Hanger	9300210 (6)	9300210 (8)
Screw	5183536 (12)	5183536 (16)
20 Raceway Cover End Trim	---- color per order ----	
21 Raceway Cover Retainer	9023841 (4)	9023841 (6)
22 Screw	5183536 (8)	5183536 (12)
23 Metal Kickplate, Ptd.	9324399	9324406
Kickplate Joint Trim, Ptd.	9324550	9324550
Screw, BLK.	9324612 (6)	9324612 (6)
24 Shoulder Screw	9025833 (6)	9025833 (8)
25 Kickplate Support Assy.	(3)	(4)
26 Raceway Cover	---- color per order ----	
27 Shoulder Screw	9025833 (18)	9025833 (26)
28 Front Cladding, Ptd. (NFX/NFSX/NCSX)	9025637	9025638

Installation & Service Manual

Item Description	8'	12'
Front Cladding, Ptd, (NFSGX/NCSGX)	9036715	9036716
29 Bumper	---- color per order ----	---- color per order ----
30 Color Band, Ptd. (NFX/NFSX/NCSX)	9023798	9023800
31 Bumper Retainer/Hand Rail	---- color per order ----	---- color per order ----
Bumper Retainer	9025058	9025061
32 Bumper End Trim	---- color per order ----	---- color per order ----
33 Glass Trim (NFSGX/NCSGX)	9031808	9031808
34 Screw	5048626 (2)	5048626 (2)
35 Color Band, Ptd (NFSGX/NCSGX)	9020971	9020972
Color Band Backer (NFSGX/NCSGX)	9025982	9025982

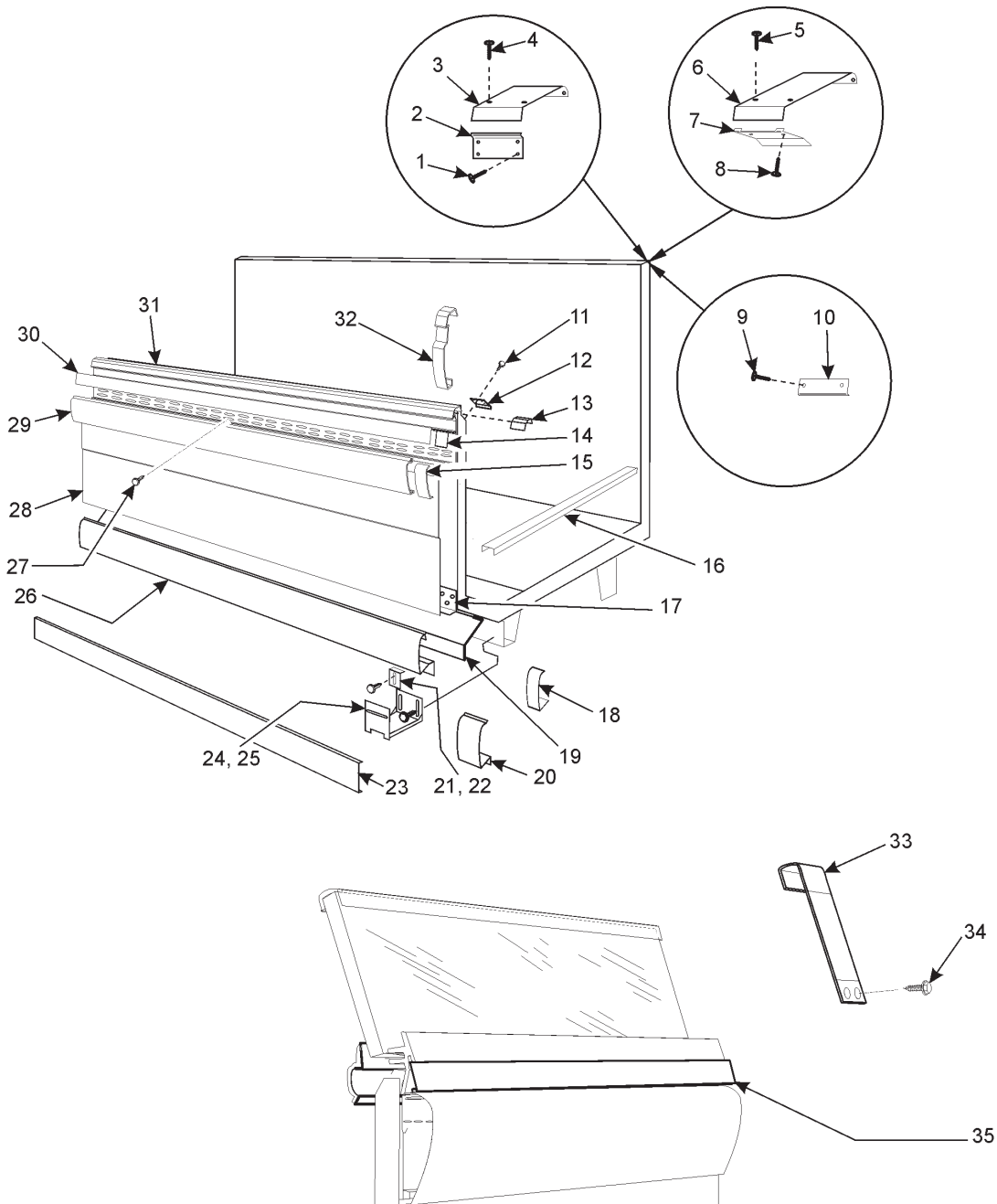

Operational Parts List

(Models NFX/NFSX/NCSX/NFSGX/NCSGX)

Case Usage	Domestic		Export	
	115 Volt 60 Hertz		220 Volt 50 Hertz	
Case Size	8'	12'	8'	12'
Fan Motor	5125532 5 Watt	5125532 5 Watt	5126572 5 Watt	5126572 5 Watt
Fan Motor Brackets	5213132	5213132	5213132	5213132
Fan Bracket Plate	9041077	9041077	9041077	9041077
Fan Blades (6" 21° 3B)	5105621	5105621	----	----
(6" 27° 3B)	----	----	5104294	5104294
Opt. ECM Fan Motor	9025002 8 Watt	9025002 8 Watt	----	----
Opt. ECM Fan Motor Brackets	5205279	5205279	----	----
Opt. ECM Fan Blades (6" 25 1/4° 3B)	9025138	9025138	----	----
Anti-Sweat Heater Wire (Hi-Watt)	5124818	5124819	5081149	5081150
(Lo-Watt)	5124216	5124217	5081147	5081148
(glass retainer) (NFSGX/NCSGX)	5218331	5218332	5081149	5081150
Electric Def. Heater	5960934	5960935	5088278	5088279
Electric Def. Term. Klixon	5125211	5125211	5125211	5125211
Opt. Gas Def. Fan Delay Klixon	9023503	9023503	9023503	9023503
Opt. Gas Def. Term. Klixon	9023508	9023508	9023508	9023508
T-8 Electronic Ballast (NFS(G)X/NCS(G)X) (rear shelf)	5991029	5991030	9028437	9028438
T-8 Lampholder	5092414	5092414	5092414	5092414
NSF Product Thermometer	5967100	5967100	5967100	5967100

For information on operational parts not listed above contact the TYLER Service Parts Department.