

SPECIFICATION SHEET

- **NFJGCX/NCJGCX GLASS FRT JUMBO ISLAND FF/IC/MED TEMP MERCHANDISERS** •
- **NTJGCX/NFMJGCX GLASS FRT JUMBO ISLAND DUAL TEMP SPLIT COIL MERCHANDISERS** •
- **NFJGECX/NCJGECX GLASS FRT JUMBO ISLAND FF/IC/MED TEMP END MERCHANDISERS** •

Refrigeration Data:

MODEL	CASE LENGTH	CASE USAGE	CAPACITY (BTUH / FT)*		EVAPORATOR (°F)	UNIT SIZING (°F)	DISCHARGE AIR		AVG. REF. CHARGE (LBS/FT)
			PARALLEL	CONVENTIONAL			TEMPERATURE (°F)	VELOCITY (FPM)	
NFJGCX	8', 12'	FROZEN	643	671	-25**	-28	-15	246***	0.85
NCJGCX	8', 12'	ICE CREAM	759	778	-35**	-38	-25	246***	0.85
NFJGCX	8', 12'	MED TEMP	552	566	+15**	+13	+22	246***	0.85
NFJGCX/ NFMJGCX	8', 12'	FROZ / MED TEMP	322 / 276	336 / 283	-25 / +15**	-28 / +13	-15 / +22	246***	0.43 / 0.43
NTJGCX	8', 12'	FROZ / ICE CRM	322 / 379	336 / 389	-25 / -35**	-28 / -38	-15 / -25	246***	0.43 / 0.43
NFJGECX	77 1/2"	FROZEN	1,929****	2,013****	-25**	-28	-15	242***	0.35
NCJGECX	77 1/2"	ICE CREAM	2,276****	2,334****	-35**	-38	-25	242***	0.35
NFJGECX	77 1/2"	MED TEMP	1,656****	1,698****	+15**	+13	+22	242***	0.35

* For sizing all refrigeration equipment other than TYLER, use conventional BTUH values.
 ** Evaporator temperature is based on the saturated pressure leaving the case.
 *** Air velocity is measured 1 hour after defrost at the Discharge Air Ducts.
 **** BTUH rating is for entire end case. Stand alone end cases require higher capacity loads. ADD 40.9% to frozen NFJGECX loads; ADD 52% to ice cream NCJGECX loads; ADD 45.8% to medium temp NFJGECX loads.

FOR SPECIFIC COMPRESSOR SIZING INFORMATION, REFER TO TYLER APPLICATIONS FOR RACK SYSTEM COMPRESSORS AND/OR THE COMPRESSOR MANUFACTURERS FOR SINGLE COMPRESSORS. FOR LINE SIZING INFORMATION, REFER TO THE MISCELLANEOUS SECTION "BUFF" IN THE TYLER SPECIFICATION GUIDE.

Electrical Data:

Fans (120 Volt) and Optional T-8 Lighting with Electronic Ballasts (120 Volt)

MODEL	CASE LENGTH	FANS / CASE	TOTAL FOR STANDARD FANS		TOTAL FOR ECM FANS		T-8 LIGHTING FOR OPT. SUPERSTRUCTURE	
			AMPS	WATTS	AMPS	WATTS	AMPS	WATTS
N(F/C/T/FM)JGCX	8'	4	1.36	120.8	0.48	13.6	2.00	240.0
N(F/C/T/FM)JGCX	12'	6	2.04	181.2	0.72	20.4	3.00	360.0
NFJGECX	77 1/2"	2	0.68	60.4	0.24	6.8	0.30	36.0

Heaters (120 and 208 Volt)

MODEL	CASE LENGTH	ANTI-SWEAT HEATERS (120 V)						HEATED GLASS (120V)*		DEFROST HEATERS (208 V)				DRAIN PAN HEATER (120V) HG	
		DISCHARGE AIR		GLASS RETAINER		OPT. SUPERSTRUCTURE				COIL		DRAIN PAN (208V) Elec			
		AMPS	WATTS	AMPS	WATTS	AMPS	WATTS	AMPS	WATTS	AMPS	WATTS	AMPS	WATTS	AMPS	WATTS
NFJGCX/NFMJGCX	8'	1.92	230.4	1.88	226.2	3.80	456.0	1.32	158.0	13.80	2,860	2.24	466	5.00	600
NCJGCX/NTJGCX	8'	1.92	230.4	1.88	226.2	3.80	456.0	1.32	158.0	21.64	4,500	2.88	600	5.00	600
NFJGCX/NFMJGCX	12'	2.54	304.8	2.50	300.0	5.20	324.0	1.98	238.0	20.60	4,290	3.36	700	7.50	900
NCJGCX/NTJGCX	12'	2.54	304.8	2.50	300.0	5.20	324.0	1.98	238.0	34.62	7,200	4.33	900	7.50	900
NFJGECX/NCJGECX	77 1/2"	0.39	47.0	1.16	138.0	1.30	156.0	0.93	111.6	7.81	1,624	N/A	N/A	N/A	N/A

* Heated glass should be disconnected in case or case sections during medium temperature operation.

CASE CIRCUITS: In addition to a 208V defrost circuit, there is the 120V case fan circuit plus the 120V case anti-sweat circuit. Cases with Gas Defrost have a separate 120V circuit for the drain pan heater. Shelf or canopy lights require a separate 120V circuit which can be switched at the back room for convenience in controlling the lights.

208 VOLT DEFROST (AMPS)														
FEET	8	12	16	20	24	28	32	36	40	44	48	52		
FF/MED 1 PH	16.0 TG-30	24.0 TG-30	32.0 TG-40	40.0 TG-50	(Separate circuit recommended due to high amp draw) N/A									
FF/MED 3 PH	12.1 TG-3-30	20.7 TG-3-30	18.6 TG-3-30	18.2 TG-3-30	31.1 TG-3-40	32.8 TG-3-40	37.0 TG-3-50	15.6/15.6 TG-3-30-30	15.6/24.2 TG-3-30-30	26.8/26.8 TG-3-40-40	31.0/31.0 TG-3-40-40	32.0/32.0 TG-3-40-40		
IC 1 PH	24.5 TG-30	38.9 TG-50	(Separate circuit recommended due to high amp draw) N/A											
IC 3 PH	21.0 TG-3-30	34.0 TG-3-50	32.0 TG-3-40	38.0 TG-3-50	34/34 TG-3-40-40	28/28 TG-3-40-40	34/34 TG-3-40-40	34/34 TG-3-40-40	38/38 TG-3-50-50	34/34/34 TG-3-40-40-40	34/34/34 TG-3-40-40-40	38/38/38 TG-3-50-50-50		

UL SANITATION approved in accordance with ANSI/NSF – 7.

CASE BTUH REQUIREMENTS are calculated to produce approximately the indicated entering-air temperature with absolute maximum operating ambient limits of **75°F & 55RH**.

The information contained herein is based on technical analysis and/or tests performed in a controlled lab environment that are consistent with industry practices, and is intended as a reference for system sizing and configuration purposes only and for use by persons having technical skill at their own discretion and risk. Conditions of use are outside of Tyler's control and we do not assume and hereby disclaim any liability for results obtained or damages incurred through application of or reliance on the data presented, including but not limited to specific energy consumption with any particular model or installed application. SPECIFICATIONS ARE SUBJECT TO CHANGE WITHOUT NOTICE.

CASE-TO-CASE SUCTION LINE SUB-FEED BRANCH LINE SIZING											
FEET	8	12	16	20	24	28	32	36	40	44	48
R404A FF	7/8"	7/8"	1 1/8"	1 1/8"	1 1/8"	1 3/8"	1 3/8"	1 3/8"	1 3/8"	1 3/8"	1 5/8"
R404A IC	7/8"	1 1/8"	1 1/8"	1 3/8"	1 3/8"	1 3/8"	1 3/8"	1 5/8"	1 5/8"	1 5/8"	1 5/8"
R22 MED	1/2"	5/8"	5/8"	7/8"	7/8"	7/8"	7/8"	7/8"	7/8"	7/8"	7/8"

Defrost Data:

DEFROST TYPE	DEFROSTS PER DAY	DURATION TIME (MIN)	TERMINATION TEMP. (°F)	EPR SETTINGS **		DEFROST WATER (LB / FT / DAY)
				R22 (PSIG)	R404A (PSIG)	
ELECTRIC / FF	1	60	50	7	14	0.68
ELECTRIC / IC	1	36	50	3	8	0.58
ELECTRIC / MED	1	36	50	37	50	0.45
HOT GAS / FF	2-3	20-25	55*	7	14	0.68
HOT GAS / IC	2-3	25-30	55*	3	8	0.58
HOT GAS / MED	2-3	16-20	55*	37	50	0.45

* If an Electronic Sensor is used for termination, it should be set at 65°F termination temperature.
 ** Set EPR to give this pressure at the case.

NFJGCX / NCJGCX / NFMJGCX / NTJGCX APPLICATIONS:

The NFJGCX, NCJGCX, NFMJGCX and NTJGCX cases can be used in a wide variety of applications as described below:

- NFJGCX/NCJGCX:** These models have front and rear coils piped together and both wells are run off one compressor system. Always pipe the compressor system that will supply the coldest application usage.
1. Frozen food on both sides.
 2. Ice cream on both sides. (NCJGCX only)
 3. Medium temp on both sides. No dual temp control is needed, but you must specify the proper expansion valve and size the compressor system accordingly. **NOTE:** Disconnect the heated glass when using this case at medium temp.
 4. Frozen food on one side and ice cream on the other side. (NCJGCX only)
 5. Frozen food on one side and medium temp on the other side. **NOTE:** Disconnect the heated glass on the medium temp side.
 6. Frozen food on one side and dual temp on the other side. **NOTE:** Dual temp refers to frozen food or medium temp operation by use of a dual temp control. Dual temp also requires an expansion valve sized for the coldest dual temp operation. The dual temp control will automatically disconnect the heated glass during medium temp operation.
 7. Dual temp on both sides. **NOTE:** This requires either one or two dual temp controls. Use one dual temp control when both wells are controlled together. Use two separate dual temp controls when you want to control the front and rear wells separately on one compressor.

NTJGCX/NFMJGCX: These models have the front and rear coils piped separately. This case is designed to run off separate compressor systems and operate in dual temp applications. In addition, this version has an insulated center partition to aid in maintaining the temperature differences between the two sides. Both sides must defrost at the same time.

TYPICAL USAGES:

1. Frozen food on one side and ice cream on the other side. (NTJGCX only)
2. Frozen food on one side and medium temp on the other side. (NFMJGCX only) **NOTE:** Disconnect the heated glass on the medium temp side.
3. Frozen food on one side and dual temp on the other side. **NOTE:** Dual temp refers to frozen food or medium temp operation by use of a dual temp control. Dual temp also requires an expansion valve sized for the coldest dual temp operation. The dual temp control will automatically disconnect the heated glass during medium temp operation.
4. Dual temp on both sides. **NOTE:** This requires two dual temp controls to control both the front and rear wells on their respective compressor systems.

NON-TYPICAL USAGES:

5. Frozen food on both sides.
6. Ice cream on both sides. (NTJGCX only)
7. Medium temp on both sides. No dual temp control is needed, but you must specify the proper expansion valve and size each compressor system accordingly. (NFMJGCX only) **NOTE:** Disconnect the heated glass when using this case at medium temp.

DEFROST WIRING: There are two heaters circuits in each case. The heater wiring stubs out in the 208V raceway as two pairs of wires. Defrost circuits can therefore be wired as a single phase load or they can be wired as an unbalanced 3-phase load. The 3-phase defrost information is based on dividing the heater loads as evenly as possible across the phases.

NOTE: Optional shelving superstructures with lights have the same electrical requirements per row of lights as the amps shown.

NFJGCX/NCJGCX/NTJGCX/NFMJGCX CROSS SECTION

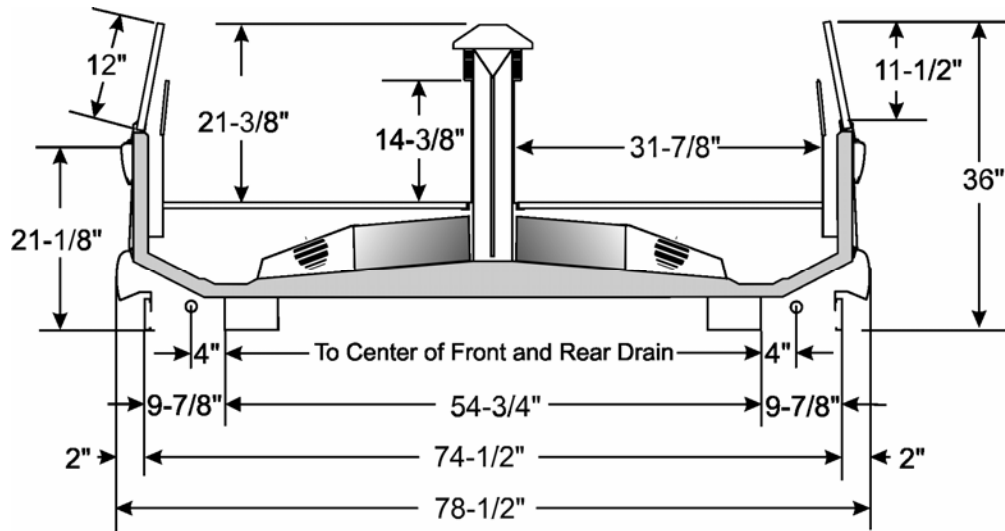

NFJGCX/NCJGCX/NTJGCX/NFMJGCX FLOOR PLAN

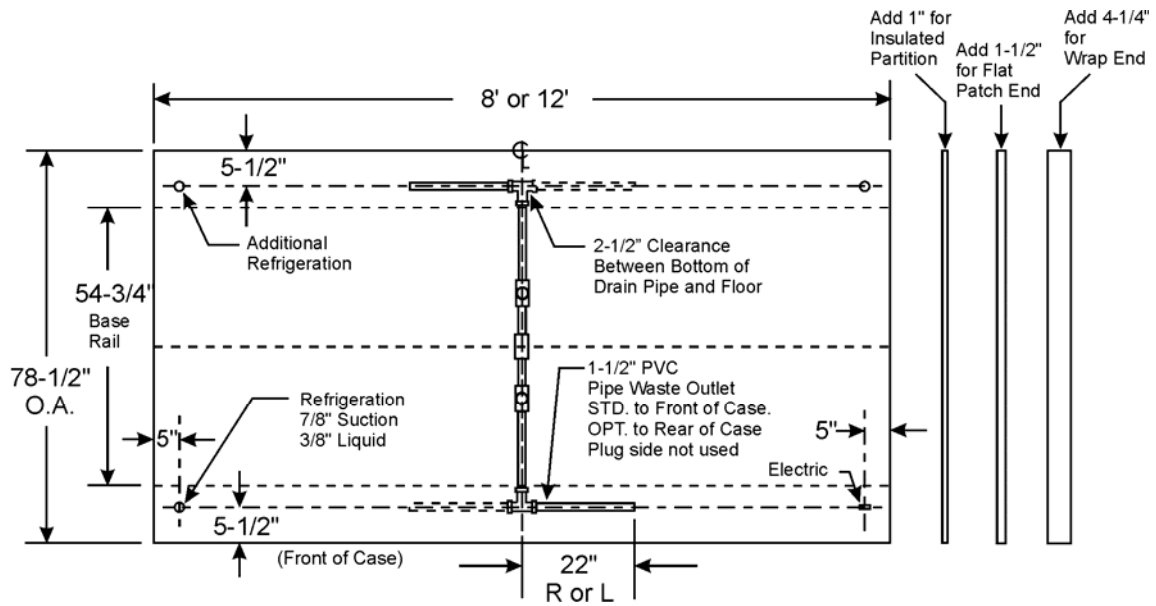

NFJGECX/NCJGECX END CASE CROSS SECTION

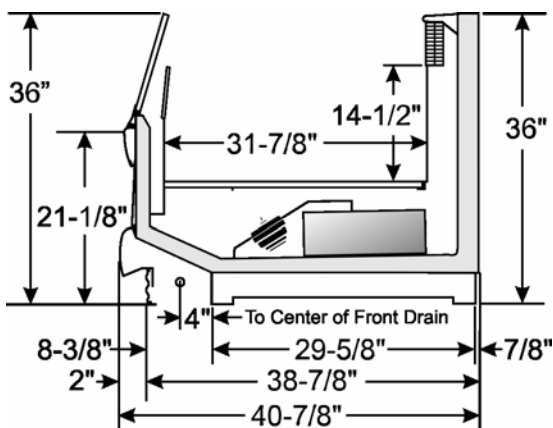

NFJGECX/NCJGECX END CASE FLOOR PLAN

