



SPECIFICATION SHEET

- **NFJGA/NCJGA GLASS FRT JUMBO ISLAND FF/IC/MED TEMP MERCHANDISERS •**
- **NTJGA/NFMJGA GLASS FRT JUMBO ISLAND DUAL TEMP SPLIT COIL MERCHANDISERS •**
- **NFJGEA/NCJGEA GLASS FRT JUMBO ISLAND FF/IC/MED TEMP END MERCHANDISERS •**

Refrigeration Data:

MODEL	CASE LENGTH	CASE USAGE	CAPACITY (BTUH / FT)*		EVAPORATOR (°F)	UNIT SIZING (°F)	DISCHARGE AIR		AVG. REF. CHARGE (LBS/FT)
			PARALLEL	CONVENTIONAL			TEMPERATURE (°F)	VELOCITY (FPM)	
NFJGA	8', 12'	FROZEN	643	671	-25**	-28	-15	290***	0.85
NCJGA	8', 12'	ICE CREAM	759	778	-35**	-38	-25	290***	0.85
NFJGA	8', 12'	MED TEMP	552	566	+15**	+13	+22	290***	0.85
NFJGA/ NFMJGA	8', 12'	FROZ / MED TEMP	322 / 276	336 / 283	-25 / +15**	-28 / +13	-15 / +22	290***	0.43 / 0.43
NTJGA	8', 12'	FROZ / ICE CRM	322 / 379	336 / 389	-25 / -35**	-28 / -38	-15 / -25	290***	0.43 / 0.43
NFJGEA	77 1/2"	FROZEN	2,718****	2,836****	-25**	-28	-15	290***	0.35
NCJGEA	77 1/2"	ICE CREAM	3,459****	3,548****	-35**	-38	-25	290***	0.35
NFJGEA	77 1/2"	MED TEMP	2,414****	2,476****	+15**	+13	+22	290***	0.35

* For sizing all refrigeration equipment other than TYLER, use conventional BTUH values.
 ** Evaporator temperature is defined as the saturated suction temperature leaving the case.
 *** Air velocity is measured 1 hour after defrost at the Discharge Air Ducts.
 **** BTUH rating is for entire end case.

FOR SPECIFIC COMPRESSOR SIZING AND/OR LINE SIZING INFORMATION, REFER TO THE "GOLD" AND/OR "BUFF" SECTIONS IN THE TYLER SPECIFICATION GUIDE.

Electrical Data:

Fans (120 Volt) and Optional T-8 Lighting with Electronic Ballasts (120 Volt)

MODEL	CASE LENGTH	FANS / CASE	TOTAL FOR STANDARD FANS		TOTAL FOR ECM FANS		T-8 LIGHTING FOR OPT. SUPERSTRUCTURE	
			AMPS	WATTS	AMPS	WATTS	AMPS	WATTS
N(F/C/T/FM)JGA	8'	4	1.36	120.8	0.88	44.0	2.00	240.0
N(F/C/T/FM)JGA	12'	6	2.04	181.2	1.32	66.0	3.00	360.0
NFJGEA	77 1/2"	2	0.68	60.4	0.44	22.0	0.30	36.0

Heaters (120 and 208 Volt)

MODEL	CASE LENGTH	ANTI-SWEAT HEATERS (120 V)						HEATED GLASS (120V)*		DEFROST HEATERS (208 V)				DRAIN PAN HEATER (120V) HG	
		DISCHARGE AIR		GLASS RETAINER		OPT. SUPERSTRUCTURE				COIL		DRAIN PAN (208V) Elec			
		AMPS	WATTS	AMPS	WATTS	AMPS	WATTS	AMPS	WATTS	AMPS	WATTS	AMPS	WATTS	AMPS	WATTS
NFJGA/NFMJGA	8'	1.92	230.4	1.88	226.2	3.80	456.0	1.32	158.0	13.80	2,860	2.24	466	5.00	600
NCJGA/NTJGA	8'	1.92	230.4	1.88	226.2	3.80	456.0	1.32	158.0	21.64	4,500	2.88	600	5.00	600
NFJGA/NFMJGA	12'	2.54	304.8	2.50	300.0	5.20	324.0	1.98	238.0	20.60	4,290	3.36	700	7.50	900
NCJGA/NTJGA	12'	2.54	304.8	2.50	300.0	5.20	324.0	1.98	238.0	34.62	7,200	4.33	900	7.50	900
NFJGEA/NCJGEA	77 1/2"	0.40	48.0	1.28	153.6	1.30	156.0	0.93	111.6	8.60	1,788	N/A	N/A	N/A	N/A

* Heated glass should be disconnected in case or case sections during medium temperature operation.

CASE CIRCUITS: In addition to a 208V defrost circuit, there is the 120V case fan circuit plus the 120V case anti-sweat circuit. Cases with Gas Defrost have a separate 120V circuit for the drain pan heater. Shelf or canopy lights require a separate 120V circuit which can be switched at the back room for convenience in controlling the lights.

208 VOLT DEFROST (AMPS)														
FEET	8	12	16	20	24	28	32	36	40	44	48	52		
FF/MED 1 PH	16.0 TG-30	24.0 TG-30	32.0 TG-40	40.0 TG-50	(Separate circuit recommended due to high amp draw)									
	N/A													
FF/MED 3 PH	12.1 TG-3-30	20.7 TG-3-30	18.6 TG-3-30	18.2 TG-3-30	31.1 TG-3-40	32.8 TG-3-40	37.0 TG-3-50	15.6/15.6 TG-3-30-30	15.6/24.2 TG-3-30-30	26.8/26.8 TG-3-40-40	31.0/31.0 TG-3-40-40	32.0/32.0 TG-3-40-40		
IC 1 PH	24.5 TG-30	38.9 TG-50	(Separate circuit recommended due to high amp draw)											
	N/A													
IC 3 PH	21.0 TG-3-30	34.0 TG-3-50	32.0 TG-3-40	38.0 TG-3-50	34/34 TG-3-40-40	28/28 TG-3-40-40	34/34 TG-3-40-40	34/34 TG-3-40-40	38/38 TG-3-50-50	34/34/34 TG-3-40-40-40	34/34/34 TG-3-40-40-40	38/38/38 TG-3-50-50-50		

CASE BTUH REQUIREMENTS are calculated to produce approximately the indicated entering-air temperature with absolute maximum operating ambient limits of **75°F & 55RH**.

The information contained herein is based on technical data and tests that we believe are reliable, and is intended for use by persons having technical skill at their own discretion and risk. Since conditions of use are outside of Tyler's control, we cannot assume any liability for results obtained or damages incurred through the applications of the data presented. SPECIFICATIONS ARE SUBJECT TO CHANGE WITHOUT NOTICE.

CASE-TO-CASE SUCTION LINE SUB-FEED BRANCH LINE SIZING											
FEET	8	12	16	20	24	28	32	36	40	44	48
R404A FF	7/8"	7/8"	1 1/8"	1 1/8"	1 1/8"	1 3/8"	1 3/8"	1 3/8"	1 3/8"	1 3/8"	1 5/8"
R404A IC	7/8"	1 1/8"	1 1/8"	1 3/8"	1 3/8"	1 3/8"	1 3/8"	1 5/8"	1 5/8"	1 5/8"	1 5/8"
R22 MED	1/2"	5/8"	5/8"	7/8"	7/8"	7/8"	7/8"	7/8"	7/8"	7/8"	7/8"

Defrost Data:

DEFROST TYPE	DEFROSTS PER DAY	DURATION TIME (MIN)	TERMINATION TEMP. (°F)	EPR SETTINGS **		DEFROST WATER (LB / FT / DAY)
				R22 (PSIG)	R404A (PSIG)	
ELECTRIC / FF	1	60	50	7	14	0.68
ELECTRIC / IC	1	36	50	3	8	0.58
ELECTRIC / MED	1	36	50	37	50	0.45
HOT GAS / FF	2-3	20-25	55*	7	14	0.68
HOT GAS / IC	2-3	25-30	55*	3	8	0.58
HOT GAS / MED	2-3	16-20	55*	37	50	0.45

* If an Electronic Sensor is used for termination, it should be set at 70°F termination temperature.

** Set EPR to give this pressure at the case.

NFJGA / NCJGA / NFMJGA / NTJGA APPLICATIONS:

The NFJGA, NCJGA, NFMJGA and NTJGA cases can be used in a wide variety of applications as described below:

NFJGA/NCJGA: These models have front and rear coils piped together and both wells are run off one compressor system. Always pipe the compressor system that will supply the coldest application usage.

1. Frozen food on both sides.
2. Ice cream on both sides. (NCJGA only)
3. Medium temp on both sides. No dual temp control is needed, but you must specify the proper expansion valve and size the compressor system accordingly. **NOTE:** Disconnect the heated glass when using this case at medium temp.
4. Frozen food on one side and ice cream on the other side. (NCJGA only)
5. Frozen food on one side and medium temp on the other side. **NOTE:** Disconnect the heated glass on the medium temp side.
6. Frozen food on one side and dual temp on the other side. **NOTE:** Dual temp refers to frozen food or medium temp operation by use of a dual temp control. Dual temp also requires an expansion valve sized for the coldest dual temp operation. The dual temp control will automatically disconnect the heated glass during medium temp operation.
7. Dual temp on both sides. **NOTE:** This requires either one or two dual temp controls. Use one dual temp control when both wells are controlled together. Use two separate dual temp controls when you want to control the front and rear wells separately on one compressor.

NTJGA/NFMJGA: These models have the front and rear coils piped separately. This case is designed to run off separate compressor systems and operate in dual temp applications. In addition, this version has an insulated center partition to aid in maintaining the temperature differences between the two sides. Both sides must defrost at the same time.

TYPICAL USAGES:

1. Frozen food on one side and ice cream on the other side. (NTJGA only)
2. Frozen food on one side and medium temp on the other side. (NFMJGA only) **NOTE:** Disconnect the heated glass on the medium temp side.
3. Frozen food on one side and dual temp on the other side. **NOTE:** Dual temp refers to frozen food or medium temp operation by use of a dual temp control. Dual temp also requires an expansion valve sized for the coldest dual temp operation. The dual temp control will automatically disconnect the heated glass during medium temp operation.
4. Dual temp on both sides. **NOTE:** This requires two dual temp controls to control both the front and rear wells on their respective compressor systems.

NON-TYPICAL USAGES:

5. Frozen food on both sides.
6. Ice cream on both sides. (NTJGA only)
7. Medium temp on both sides. No dual temp control is needed, but you must specify the proper expansion valve and size each compressor system accordingly. (NFMJGA only) **NOTE:** Disconnect the heated glass when using this case at medium temp.

DEFROST WIRING: There are two heaters circuits in each case. The heater wiring stubs out in the 208V raceway as two pairs of wires. Defrost circuits can therefore be wired as a single phase load or they can be wired as an unbalanced 3-phase load. The 3-phase defrost information is based on dividing the heater loads as evenly as possible across the phases.

NOTE: Optional shelving superstructures with lights have the same electrical requirements per row of lights as the amps shown.

NFJGA/NCJGA/NTJGA/NFMJGA CROSS SECTION

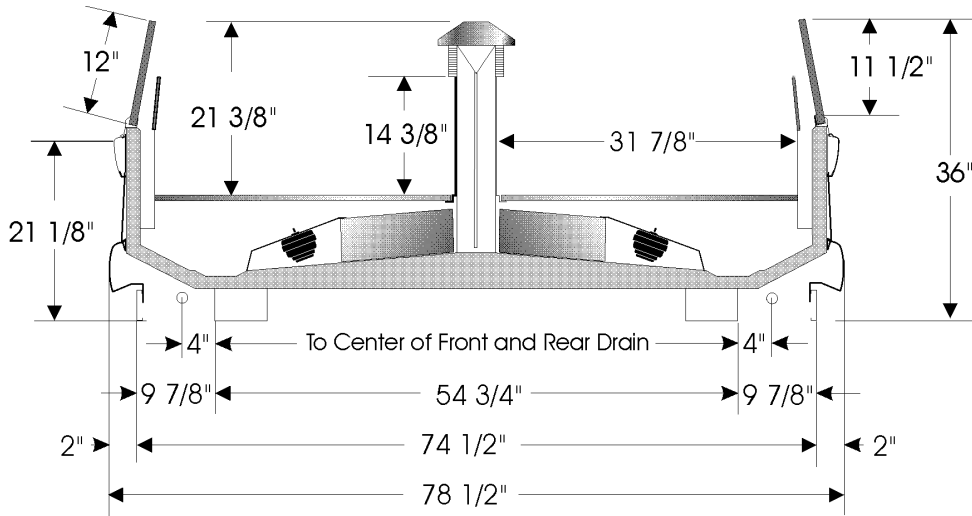

NFJGA/NCJGA/NTJGA/NFMJGA FLOOR PLAN

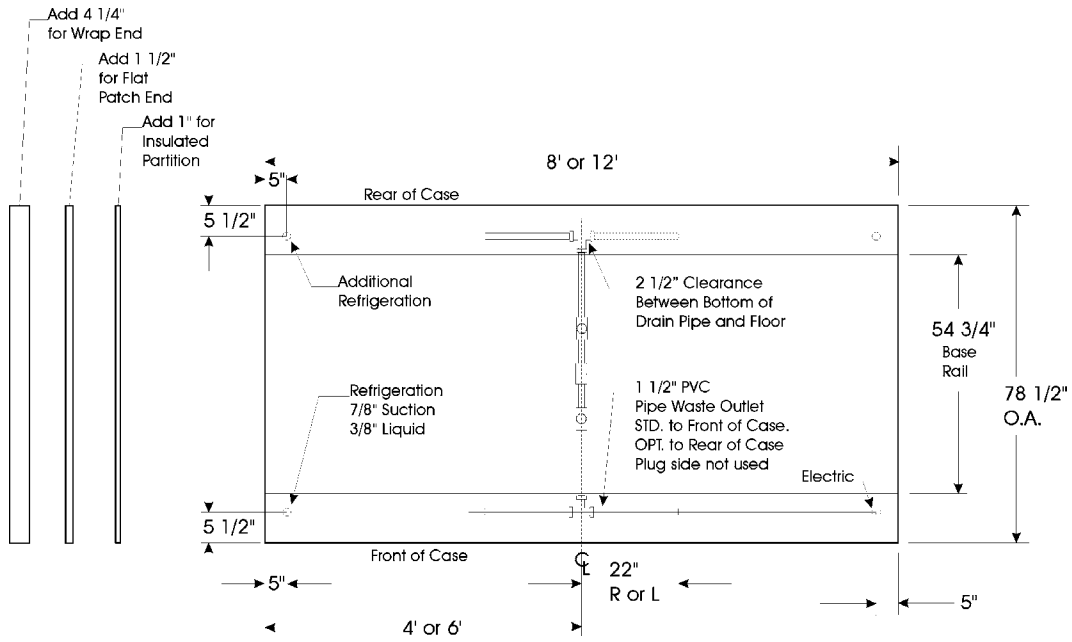

NFJGEA/NCJGEA END CASE CROSS SECTION

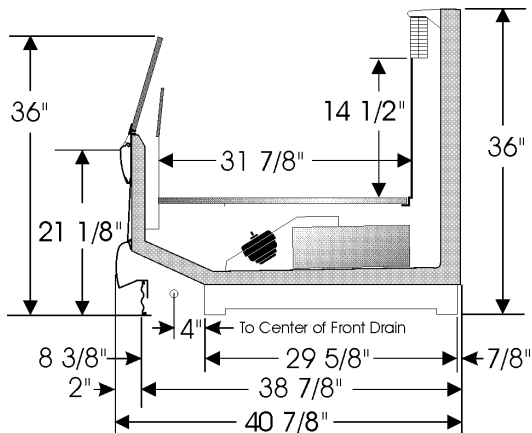

NFJGEA/NCJGEA END CASE FLOOR PLAN

