

NFM Fixed curved glass service merchandisers provide dual-coil cooling that maximizes the integrity of fresh meat products. A single sealed triple-pane front glass offers seamless front viewing while increasing the case's insulating factor, providing an energy-efficient alternative to lift glass versions.

Features & Benefits

- Energy-efficient copper tube and aluminum fin coils.
- Increased insulation factor with triple-pane sealed front glass.
- Front glass is seamless across the case length for better viewing.
- Single row of T8 top lights for increased product illumination.
- 22-1/2" clear sliding rear doors for easy access to interior.
- Easily removable interior components for quicker cleaning.
- Pipe leg base and removable kickplate facilitate cleaning under the case.
- Off-cycle defrost.

Options

- Glass windows on patch end panels.
- White powder-coated display screens.
- Step trays and food pans.
- Scale shelves.

Specifications are subject to engineering changes without notice.

Model	Case Length	Description	Capacity in Cubic Feet
NFM	4' • 6' • 8' • 12'	Fixed Curved Front Glass with std gravity & serpentine coils	14.6 • 21.9 • 29.3 • 43.8

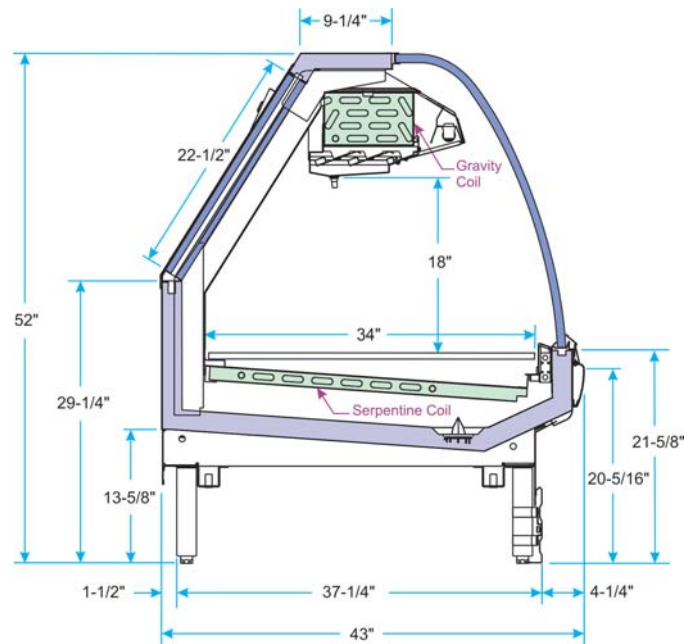

Optional Accessories



Scale Shelves add more functionality to the work area.

