

## NLBR, NLBN Lift Curved Glass



NLBR lineup shown



NLBR bakery service merchandisers provide forced air, lower-coil cooling that maximizes product integrity. The NLBN is a non-refrigerated version. The front curved glass is designed to maximize product viewing, while the glass lift system allows easy front access for stocking and merchandising of baked goods.

### Features & Benefits

- ◆ Energy-efficient copper tube and aluminum fin coils. (NLBR)
- ◆ Two rows of T8 top lights for increased product illumination.
- ◆ Patented counter-weighted mechanical hinges allow easy lifting of front glass.
- ◆ 26-1/2" clear sliding rear doors for easy access to interior.
- ◆ Easily removable interior components for quicker cleaning.
- ◆ Pipe leg base and removable kickplate facilitate cleaning under the case.
- ◆ Off-cycle defrost.

### Options

- ◆ Glass windows on patch end panels.
- ◆ ECM fan motors for additional energy savings.
- ◆ 18" or 26" lighted glass or wire screen shelving.

Specifications are subject to engineering changes without notice.

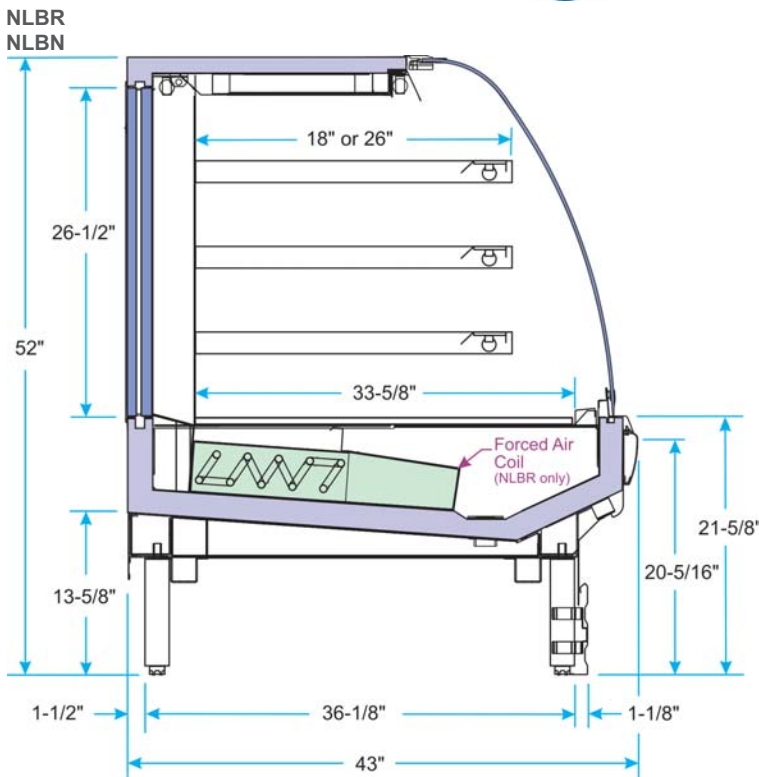

Model	Case Length	Description	Capacity in Cubic Feet*
NLBR	59" • 77"	Refrigerated Lift Curved Front Glass, standard coil	20.9 • 27.3
NLBN	59" • 77"	Non-Refrigerated Lift Curved Front Glass, standard coil	20.9 • 27.3

\* Cubic capacity is based on three rows of 26" shelves.

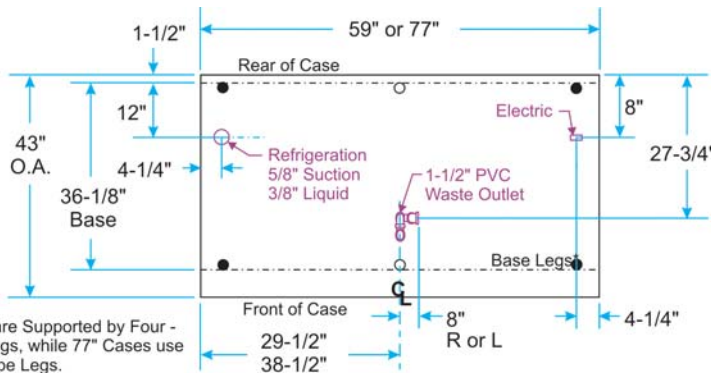

\* 59" Cases are Supported by Four - 1.5" Pipe Legs, while 77" Cases use Six - 1.5" Pipe Legs.

Add 1-1/2" for each Standard Patch End or 1" for each Insulated Partition.

### Optional Accessories



Lighted shelving enhances product presentation and maximizes merchandising space.