

NLBS bakery service merchandisers provide forced air, lower-coil cooling in a self-contained refrigeration unit that maximizes product integrity. The front curved glass is designed to maximize product viewing, while the glass lift system allows easy front access for stocking and merchandising of baked goods. Place an NLBS in those areas not supplied by system refrigeration.

Features & Benefits

- Energy-efficient copper tube and aluminum fin coils. (NLBR)
- Two rows of T8 top lights for increased product illumination.
- Patented counter-weighted mechanical hinges allow easy lifting of front glass.
- 26-1/2" clear sliding rear doors for easy access to interior.
- Easily removable interior components for quicker cleaning.
- Solid steel base adds strength and durability.
- 120 V, 60 Hz, 1 Ph, 1/4 Hp self-contained compressor system provides all the necessary refrigeration to the case.

Options

- Glass windows on patch end panels.
- ECM fan motors for additional energy savings.
- 18" or 26" lighted glass or wire screen shelving.

Specifications are subject to engineering changes without notice.

Model	Case Length	Description	Capacity in Cubic Feet*
NLBS	59" • 77"	Self-Contained Lift Curved Front Glass, standard coil	20.9 • 27.3

* Cubic capacity is based on three rows of 26" shelves.

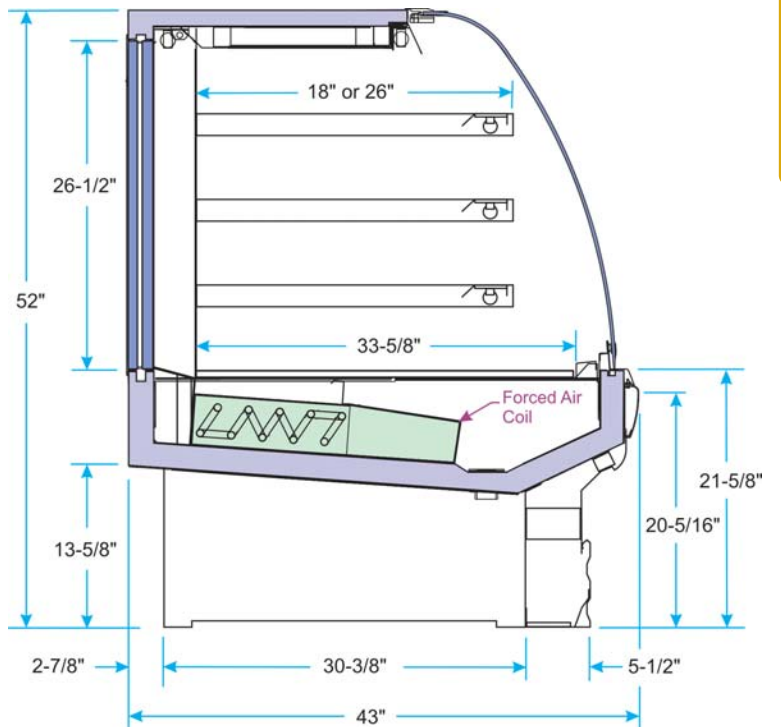

Optional Accessories



Lighted shelving enhances product presentation and maximizes merchandising space.

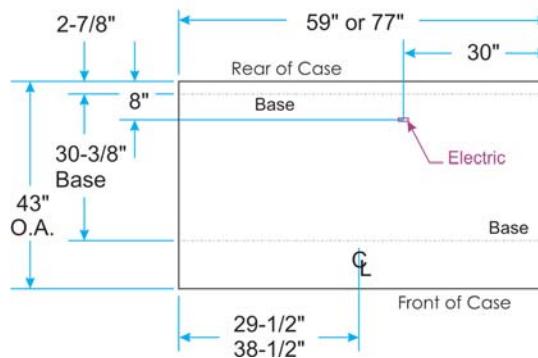

Add 1-1/2" for each Standard Patch End or 1" for each Insulated Partition.
Note: Self-Contained cases do not require a floor drain.