

SPECIFICATION SHEET

NLH LIFT FRONT CURVED GLASS HOT FOOD SERVICE MERCHANDISER

Electrical Data:

MODEL	CASE LENGTH	CASE USAGE	208/240V 1PH 3 WIRE + GROUND				208/240V 3PH 4 WIRE + GROUND			
			VOLTS	AMPS	WATTS	MAXIMUM CIRCUIT FUSE	VOLTS	AMPS	WATTS	MAXIMUM CIRCUIT FUSE
NLH	4'	HOT SERVICE CASE	208	32	6,540	40A	208	19	6,540	30A
			240	28			240	16		
NLH	6'	HOT SERVICE CASE	208	53	10,860	60A	208	31	10,860	40A
			240	46			240	27		
NLH	8'	HOT SERVICE CASE	N/A	N/A	N/A	N/A	208	43	15,180	60A
			N/A	N/A			240	37		
NLH	12'	HOT SERVICE CASE	N/A	N/A	N/A	N/A	208	60	21,600	N/A
			N/A	N/A			240	52		

NLH CROSS SECTION

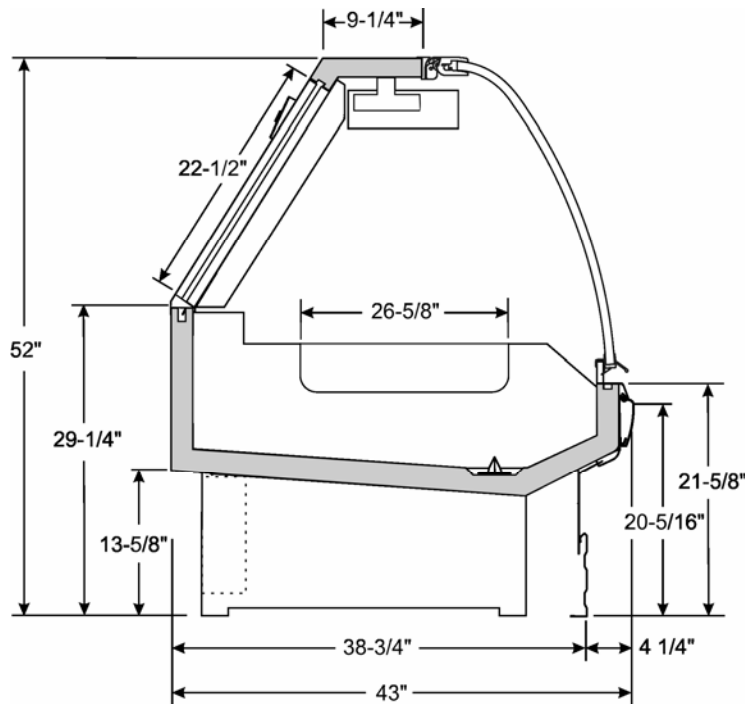

FLOOR PLAN

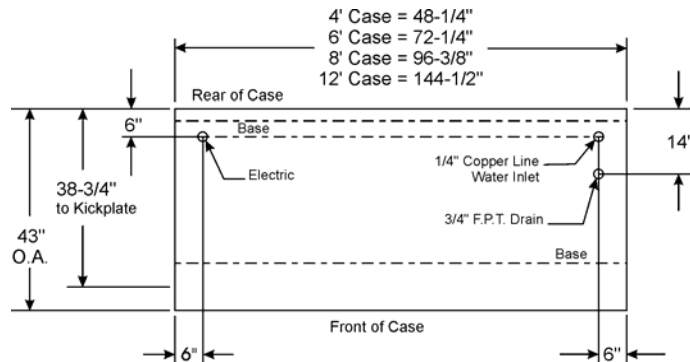

NSF CERTIFIED to meet ANSI/NSF – 4.

The information contained herein is based on technical analysis and/or tests performed in a controlled lab environment that are consistent with industry practices, and is intended as a reference for system sizing and configuration purposes only and for use by persons having technical skill at their own discretion and risk. Conditions of use are outside of Tyler's control and we do not assume and hereby disclaim any liability for results obtained or damages incurred through application of or reliance on the data presented, including but not limited to specific energy consumption with any particular model or installed application. SPECIFICATIONS ARE SUBJECT TO CHANGE WITHOUT NOTICE.