

NLH Lift Curved Glass



NLH hot food service merchandisers provide wet or dry heat evenly for a controlled, consistent environment throughout the case's interior to maximize product integrity. The front curved glass is designed to maximize product viewing, while the glass lift system allows easy front access for stocking and merchandising of baked goods.

Features & Benefits

- ◆ Dual overhead heat lamps over each food well maintain even heat distribution.
- ◆ Protected incandescent canopy lamps enhance product illumination.
- ◆ Patented counter-weighted mechanical hinges allow easy lifting of tempered, thermopane front glass.
- ◆ 22-1/2" clear sliding rear doors for easy access to interior.
- ◆ Individual thermostatically controlled food wells hold temperature and expand merchandising flexibility. Food wells may be operated wet or dry.
- ◆ Complete stainless steel interior for ease of sanitation and proper heat distribution.
- ◆ 7-3/4" full length stainless steel wrap shelf.

Options

- ◆ Automatic water level control system ensures proper water levels during wet operation.
- ◆ Full compliment of food pans are available.
- ◆ Full length, hinged poly-wrap shelf.
- ◆ Isolated ground convenience outlet.

Specifications are subject to engineering changes without notice.

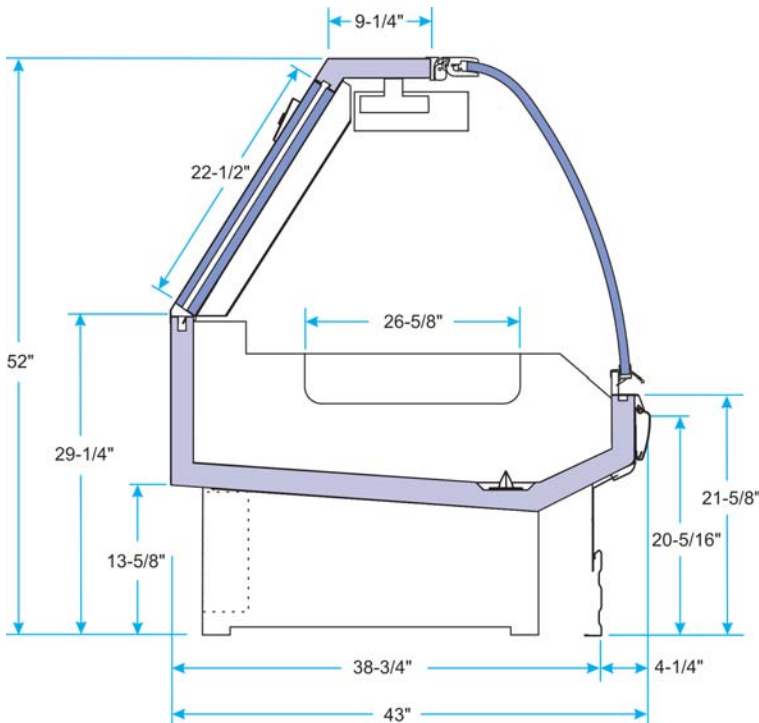

Model	Case Length	Description	Capacity in Cubic Feet
NLH4	48-1/4"	Lift Curved Front Glass with Three Hot Food Wells	N/A*
NLH6	72-1/4"	Lift Curved Front Glass with Five Hot Food Wells	N/A*
NLH8	96-3/8"	Lift Curved Front Glass with Seven Hot Food Wells	N/A*
NLH12	144-1/2"	Lift Curved Front Glass with Eleven Hot Food Wells	N/A*

* Due to the variability of individual food tray capacities, overall merchandiser cubic capacity cannot accurately be determined.

Optional Accessories



Hinged poly-wrap shelf provides a collapsible work and prep area for your service personnel.



A full compliment of food pans are available to meet all of your merchandising and service needs.