

NP



NP single-deck bulk produce merchandisers feature a variety of merchandising options that allows creative presentation of produce. In addition to serving as a standard self-service bulk produce merchandiser, the NP can be utilized to display fresh-cut products, iced melons or as an iced juice bar.

### Features & Benefits

- ♦ Energy-efficient copper tube and aluminum fin coils.
- ♦ Adjustable white powder-coated display screens enhance product presentation.
- ♦ Solid steel base adds strength and durability.
- ♦ Easily removable front and rear ducts for quicker cleaning.
- ♦ Fan assembly design allows access to coil and drain pan.
- ♦ Off-cycle defrost.

### Options

- ♦ ECM fan motors for additional energy savings.
- ♦ Step screens, fences, water spray hoses, scale hangers.

Specifications are subject to engineering changes without notice.

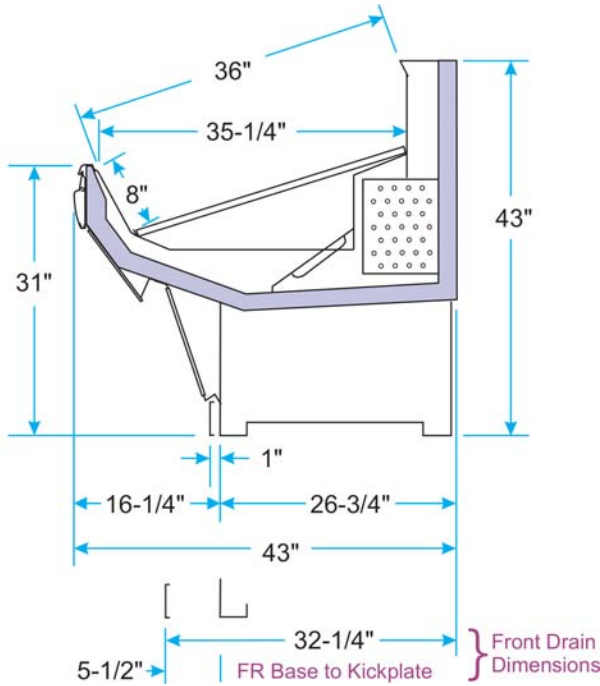

Model	Case Length	Description	Capacity in Cubic Feet
NP	8' • 12'	Single-Deck Bulk Produce, standard coil	15.6 • 23.5

Allow a 3" SPACE between the back of this case and the store wall, other cases, or coolers to minimize possible condensation problems. FORCED VENTILATION may be necessary in some situations.

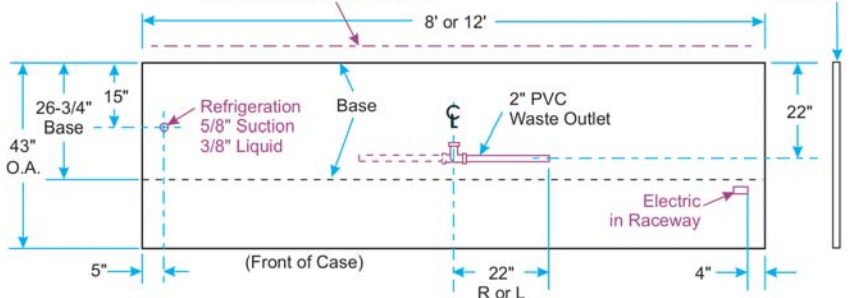

### Optional Accessories

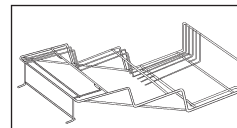

Step screens provide additional merchandising and display flexibility.



This spray hose assembly allows manual misting of bulk produce that keeps products looking fresh.

Produce