

SPECIFICATION SHEET

• P5FGN NARROW GLASS DOOR FROZEN FOOD & ICE CREAM MERCHANDISERS •

Refrigeration Data:

MODEL	CASE LENGTH	CASE USAGE	DOOR TYPE	CAPACITY (BTUH / DR)*		EVAPORATOR (°F)**	UNIT SIZING (°F)	DISCHARGE AIR (°F)	AVG. REF. CHARGE (LBS/DR)
				PARALLEL	CONVENTIONAL				
P5FGN	ALL	FROZEN	ANTHONY 101	1,400	1,446	-8	-11	1***	0.92****
P5FGN	ALL	FROZEN	ANTHONY ELM.	1,231	1,272	-7	-10	1***	0.92****
P5FGN	ALL	ICE CREAM	ANTHONY 101	1,510	1,560	-18	-21	-8***	0.92****
P5FGN	ALL	ICE CREAM	ANTHONY ELM.	1,338	1,382	-17	-20	-8***	0.92****

NOTES: * Capacity data listed is for cases with ECM fan motors and T-8 electronic vertical lighting (Prism). Prism lights should remain on at all times (24 hours) for best operation.

See Capacity Adjustments below:

ADD 90 Btuh/Dr for cases using standard fan motors.

ADD 500 Btuh per glass end for frozen food or ice cream cases.

For LED lighting that is ON 24 hours a day, DEDUCT 198 Btuh/Dr for Anthony 101 doors or DEDUCT 123 Btuh/Dr for Anthony Eliminaator doors.

** Evaporator temperature is based on the saturated pressure leaving the case.

*** DEDUCT 4 °F for cases using LED lighting in frozen food applications or 3°F for LED cases in ice cream applications.

**** This is an average refrigeration charge per door based on R22 and R404A refrigerant usage.

FOR SPECIFIC COMPRESSOR SIZING INFORMATION, REFER TO TYLER APPLICATIONS FOR RACK SYSTEM COMPRESSORS AND/OR THE COMPRESSOR MANUFACTURERS FOR SINGLE COMPRESSORS. FOR LINE SIZING INFORMATION, REFER TO THE MISCELLANEOUS SECTION "BUFF" IN THE TYLER SPECIFICATION GUIDE.

Electrical Data:

Fans and T-8 Lighting with Electronic Ballasts or LED Lighting with Electronic Drivers (120 Volt) (ANTHONY)

MODEL	NO. OF DOORS	FANS / CASE	TOTAL FOR STANDARD FANS*		TOTAL FOR ECM FANS*		VERTICAL T-8 (58-WATT)		LED LIGHTING			
			AMPS	WATTS	AMPS	WATTS	AMPS	WATTS	OPTIMAX		GELCORE	
									AMPS	WATTS	AMPS	WATTS
P5FGN	2	2	1.06	96.0	0.64	34.0	1.45	174.0	0.58	70.0	0.70	82.0
P5FGN	3	3	1.59	144.0	0.96	51.0	1.94	233.0	0.77	92.0	1.05	123.0
P5FGN	4	4	2.12	192.0	1.28	68.0	2.42	290.0	0.96	115.0	1.40	164.0
P5FGN	5	5	2.65	240.0	1.60	85.0	2.91	349.0	1.15	138.0	1.75	205.0

* The fan circuit for Electric and Gas Defrost includes the drain pan heater, which is only ON when the fans cycle OFF.

Fan circuit wire sizing should always be sized using the drain pan heater amps.

Heaters (120 and 208 Volt) (ANTHONY)

MODEL	NO. OF DOORS	ANTI-SWEAT HEATERS (120 V)										DEFROST HEATERS (208 V)**		DRAIN PAN HEATER (120 V)	
		T-8 MAIN FRAME		LED MAIN FRAME		ANTHONY 101*		ANTHONY ELIMINAATOR*		ANTHONY 2100 SERIES*		AMPS	WATTS	AMPS	WATTS
		AMPS	WATTS	AMPS	WATTS	AMPS	WATTS	AMPS	WATTS	AMPS	WATTS				
P5FGN	2	1.31	157	1.14	138	1.45	174	0.51	62	1.80	216	5.77	1,200	1.14	137
P5FGN	3	2.02	242	1.79	216	2.18	262	0.77	92	2.70	324	9.50	1,975	1.88	226
P5FGN	4	2.76	331	2.29	275	2.91	349	1.03	123	3.60	432	13.10	2,725	2.60	311
P5FGN	5	3.47	416	2.87	345	3.64	437	1.28	154	4.50	540	16.83	3,500	3.33	400

* Only door anti-sweat heaters are cyclable. ** The drain pan heater cycles OFF when the fans cycle ON.

*** If fans and main frame anti-sweats share the same power supply, make sure to add the electrical usages when sizing the electrical circuits.

Please note this is not a recommended practice.

208 VOLT DEFROST (AMPS)															
DRS	2-5	6	7	8	9	10	11	12	13	14	15	16	17		
FF/IC 1 PH	(See Def. Heaters in chart above.)	19.0 TG-30	22.6 TG-30	26.3 TG-40	29.9 TG-40	33.7 TG-50	35.8 TG-50	39.4 TG-50	(Separate circuit recommended due to high amp draw.)						
FF/IC 3 PH	N/A	16.5 TG-3-30	19.6 TG-3-30	22.8 TG-3-30	25.9 TG-3-40	29.2 TG-3-40	22.8 TG-3-30	25.9 TG-3-40	29.2 TG-3-40	29.2 TG-3-40	29.2 TG-3-40	31.0 TG-3-40	34.2 TG-3-50		
CASE-TO-CASE SUCTION LINE SUB-FEED BRANCH LINE SIZING															
R404A FF	5/8"	7/8"	7/8"	7/8"	7/8"	7/8"	1-1/8"	1-1/8"	1-1/8"	1-1/8"	1-1/8"	1-1/8"	1-1/8"	1-3/8"	
R404A IC	5/8"	7/8"	7/8"	7/8"	7/8"	1-1/8"	1-1/8"	1-1/8"	1-1/8"	1-1/8"	1-1/8"	1-1/8"	1-3/8"	1-3/8"	

CASE CIRCUITS: This case requires a separate 120V circuit for fans, lights, anti-sweats, drain pan heater, and a 208V circuit for Electric Defrost Heaters. The fan circuit for Electric and Gas Defrost includes the drain pan heater, which is on only when the fans are off. The anti-sweat circuit feeds power to both the cyclable and non-cyclable heaters.

The temperature control mode should prevent excessively low discharge air temperatures, which irritates product frosting.

UL SANITATION approved in accordance with ANSI/NSF – 7.

CASE BTUH REQUIREMENTS are calculated to produce approximately the indicated entering-air temperature with absolute maximum operating ambient limits of **75°F & 55RH**.

The information contained herein is based on technical analysis and/or tests performed in a controlled lab environment that are consistent with industry practices, and is intended as a reference for system sizing and configuration purposes only and for use by persons having technical skill at their own discretion and risk. Conditions of use are outside of Tyler's control and we do not assume and hereby disclaim any liability for results obtained or damages incurred through application of or reliance on the data presented, including but not limited to specific energy consumption with any particular model or installed application. SPECIFICATIONS ARE SUBJECT TO CHANGE WITHOUT NOTICE.

Defrost Data:

DEFROST TYPE	DEFROSTS PER DAY	DURATION TIME (MIN)	TERMINATION TEMP. (°F)	EPR SETTINGS **		DEFROST WATER (LB / DR / DAY)
				R22 (PSIG)	R404A (PSIG)	
ELECTRIC / FF (101)	1	46	60	17.9	26.3	0.8
ELECTRIC / IC (101)	1	46	60	18.6	27.2	0.8
ELECTRIC / FF (ELMINAATOR)	1	46	60	17.2	25.5	0.8
ELECTRIC / IC (ELMINAATOR)	1	46	60	11.9	19.3	0.8
HOT GAS / FF (101)	1	18-20	55*	17.9	26.3	0.8
HOT GAS / IC (101)	1	20-25	55*	18.6	27.2	0.8
HOT GAS / FF (ELMINAATOR)	1	18-20	55*	17.2	25.5	0.8
HOT GAS / IC (ELMINAATOR)	1	20-25	55*	11.9	19.3	0.8

* If an Electronic Sensor is used for termination, it should be set at 70°F termination temperature.

** Set EPR to give this pressure at the case.

P5FGN CROSS SECTION

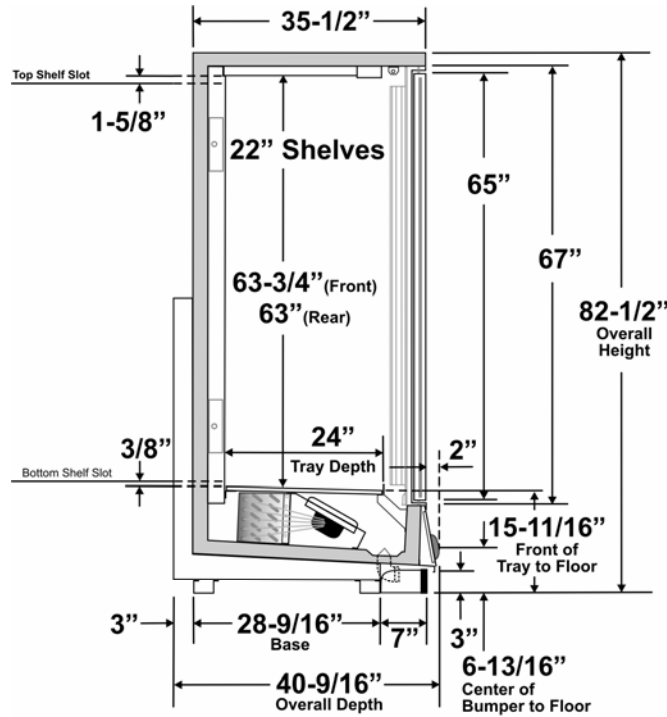

FLOOR PLAN

